



SAP Ariba 

# 2011 Release

## SAP Ariba Cloud Integration Gateway

**Presenters:** Rob Jones, Kalyan Valluri, Rajib Shome, Vick Ramburrun, Sripriya Kitambi

**Panelists :** Mamatha Vittalkar, Satheesh Gannamraju, Lovein Khullar, Kanwaljit Singh, Digvijaysinh Jadeja

9 November 2020

PUBLIC

# Important notice

The information in this presentation is confidential and proprietary to SAP and may not be disclosed without the permission of SAP. Except for your obligation to protect confidential information, this presentation is not subject to your license agreement or any other service or subscription agreement with SAP. SAP has no obligation to pursue any course of business outlined in this presentation or any related document, or to develop or release any functionality mentioned therein.

This presentation, or any related document and SAP's strategy and possible future developments, products and or platforms directions and functionality are all subject to change and may be changed by SAP at any time for any reason without notice. The information in this presentation is not a commitment, promise or legal obligation to deliver any material, code or functionality. This presentation is provided without a warranty of any kind, either express or implied, including but not limited to, the implied warranties of merchantability, fitness for a particular purpose, or non-infringement. This presentation is for informational purposes and may not be incorporated into a contract. SAP assumes no responsibility for errors or omissions in this presentation, except if such damages were caused by SAP's intentional or gross negligence.

All forward-looking statements are subject to various risks and uncertainties that could cause actual results to differ materially from expectations. Readers are cautioned not to place undue reliance on these forward-looking statements, which speak only as of their dates, and they should not be relied upon in making purchasing decisions.

# Agenda

Logistics

General Release Information

Key Feature Discussions

- Cloud Integration Gateway

Reminders

# Logistics

## To Ask a Question, please use the ON24 Q & A Panel

- If not already visible, click the Q&A button at the bottom of the screen.
- Type your question in the “Enter your question here” area.
- Click Submit.

The Presenter and/or Panelists will attempt to answer your question online or via the audio feed as close to the time the question is asked as possible.

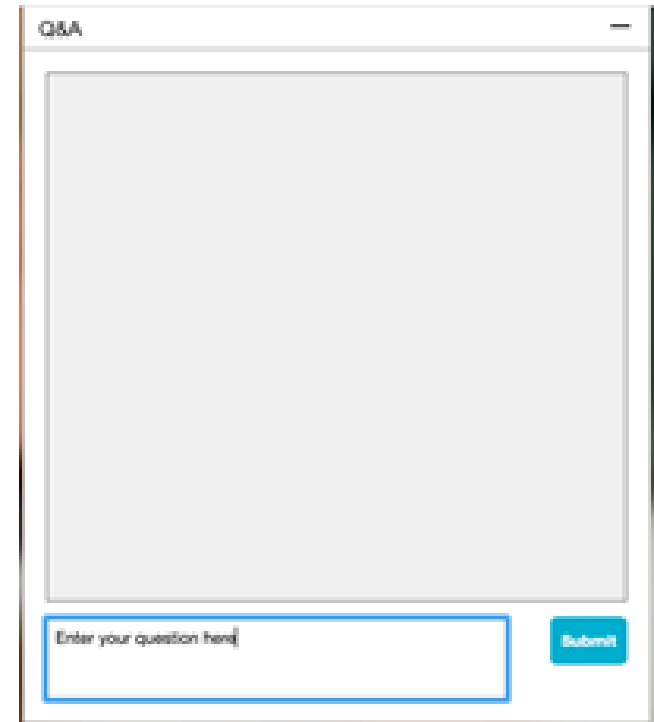
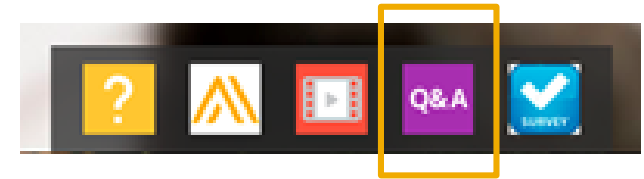

# Logistics

## At the end of the session, provide Survey feedback

- If not already visible, click the Survey button at the bottom of the screen.
- Answer the 3 questions posed.
- Click Submit.

Your feedback is used to continually improve our customer engagement activities for our quarterly product releases.

Thank you for taking the time to share your thoughts with our team!



The image shows a webinar control bar at the top with five icons: a question mark, a logo, a play button, 'Q&A', and a 'Survey' button with a checkmark. The 'Survey' button is highlighted with a yellow box. Below the bar is a survey form titled 'Survey' with the subtitle 'Event Survey'. The form contains three questions, each with a 'Select a Choice' dropdown menu, and a text area for comments. A 'Submit' button is at the bottom.

Survey

Event Survey

Your feedback on this webinar is greatly appreciated. We review every response in order to make continuous improvements to these presentations.

1. How strongly would you recommend this webinar to your peers?
2. Are you willing to be contacted to provide survey feedback on release readiness content?
3. Provide any comments you have regarding this session or the release materials:

# General Information **Session Materials**

- SAP Ariba Connect user interface
- Multiple routes for launching the Release Readiness page
- Access to product announcements also available

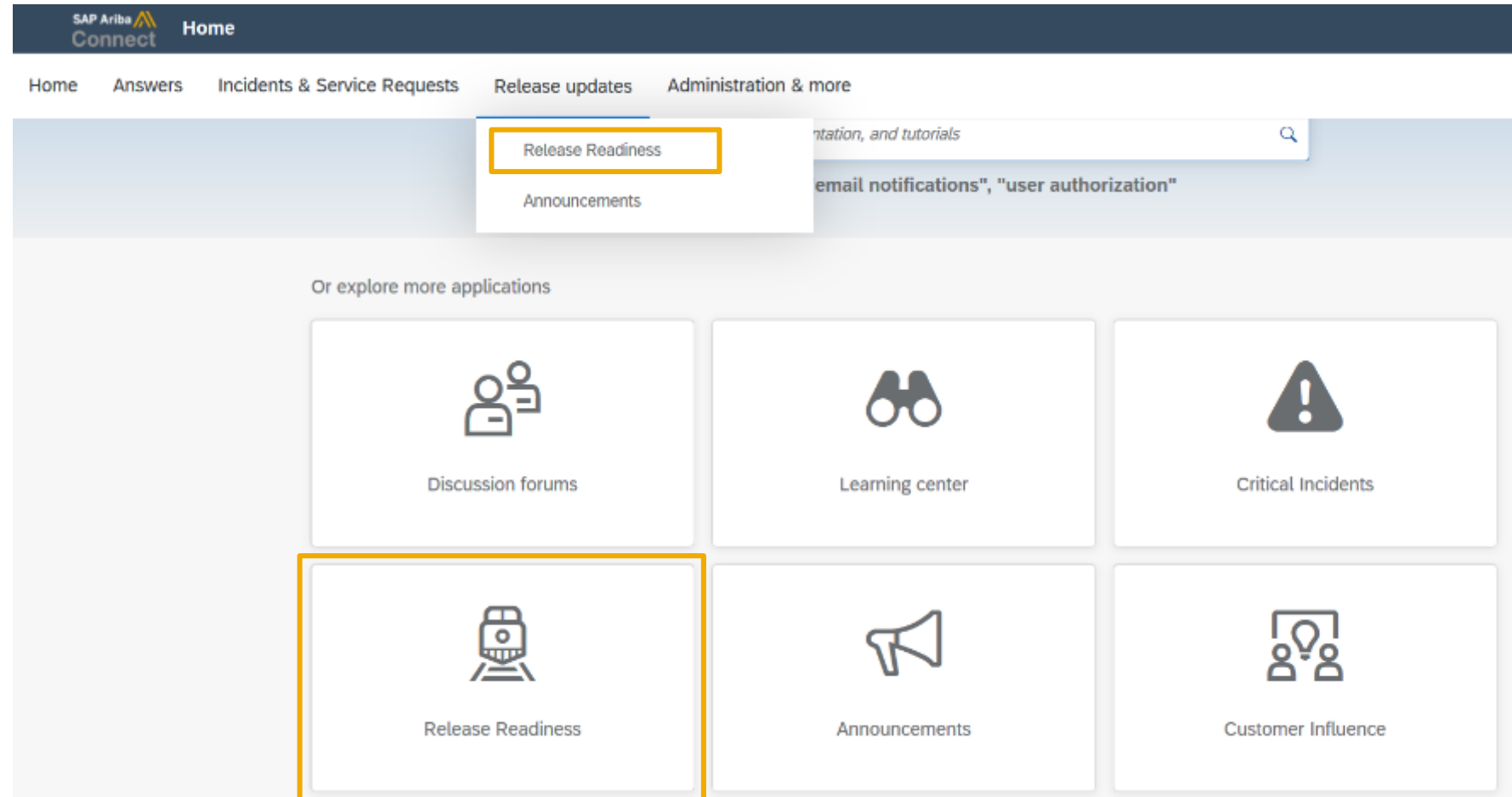

# General Information **Session Materials**

Recordings and presentations will be posted on the Release Readiness tab/tile in SAP Ariba Connect. See the Release Feature List and What's New links on the left side of the page for detailed information. Note naming convention update and visit the Previous Releases Archive and Roadmap tiles at bottom right of page.

The screenshot shows the SAP Ariba Connect interface. At the top, the navigation bar includes 'SAP Ariba Connect' and a 'Release Readiness' dropdown menu, which is circled in orange. Below the navigation bar, there are links for 'Home', 'Answers', 'Incidents & Service Requests', 'Release information', and 'Administration & more'. The main content area is titled 'Release Readiness' and includes a 'Have a question?' link. The content is divided into two main sections: 'Release Feature Content' and 'Release Calendar'.

**Release Feature Content**

- Release Feature Information**
  - What's new in the **SAP Ariba 2011** release?
    - Feature details are available on our [feature list page](#).
    - Highlights of innovation included in this release can be viewed on our [blog](#).
- What's New Guide**
  - Individual release guides have been consolidated into one convenient "[What's New in SAP Ariba](#)" guide.
  - Learn more about the benefits of the new consolidated "What's New in SAP Ariba" guide [here](#).
  - Did you know all SAP Ariba help, including product documentation, is now publicly available on the [SAP Help Portal](#) - no log in required.
- Feature Overview Webinars**
  - Register Now For The 2011 Release Feature Overview Webcasts**
  - SCHEDULE**
  - Guided Sourcing Webcast - **Thursday, Oct 29**
  - Supplier Management and Business Network Webcast - **Tuesday, Nov 3**
  - Source To Contract Webcast - **Wednesday, Nov 4**
  - Procure To Pay Webcast - **Thursday, Nov 5**
  - Cloud Integration Gateway Webcast - **Monday, Nov 9**
  - Foundation Services Webcast - **Tuesday, Nov 10**
  - Use the link below to register for one or multiple sessions.
  - [2011 Release Feature Overview Registration](#)
  - We strongly encourage you to test your computer prior to the session to ensure the minimum technical requirements are met. Look for the Test Your System link in your registration confirmation email.

**Release Calendar**

Activity	Date*
October Service Pack	10/16/2020
cXML DTD v 1.2.048 (pre-release)	10/21/2020
SAP Ariba 2011 Release	11/13/2020
December Service Pack	12/11/2020
January Service Pack	01/15/2021

[2020/2021 Release Calendar](#) [view](#)

**\*Disclaimer:** The release dates above reflect current SAP Ariba planning. A notice confirming the [quarterly release](#) dates will be sent 3-weeks prior to each release. A notice confirming the [monthly deployment](#) dates will be sent 2-weeks prior to each deployment. SAP Ariba may change the schedule at any time without notice and assumes no responsibility for errors or omissions.  
**Last updated:** Oct 22, 2020

**Additional Readiness Resources**

**Release Updates**

Updates related to the release will be added here.

Chat bot

# Success Webcast Series

- Initiated by SAP Ariba Customer Support
- Focused on specific features / process area Quick Tips
- Upcoming and previously recorded sessions
- Link to view:  
<https://gateway.on24.com/wcc/eh/1391535/SAP+Ariba+Success+Sessions>

## Success Sessions

Presented By: SAP Ariba Customer Support

Success Sessions Webcast Series. We offer Quick Tips on how to use SAP Ariba. You can browse through the topics below and make a request to [successsessions@sap.com](mailto:successsessions@sap.com).



roduction to  
ork

Supplier Success Sessions  
Invoicing



Nov 04, 2020 3:00 PM EST  
SAP Ariba: Invoicing

Supplier Success Sessions  
Participating in  
a RFI/RFP

Nov 05, 2020 1:00 PM EST  
SAP Ariba:  
an RFI/RFP



# Cloud Integration Gateway **Key Features Discussion**

- **Overview**

- ✓ **Integration Strategy**
- ✓ **Architecture**
- ✓ **Standard Integrations**
- ✓ **SAP Ariba Cloud Integration Gateway Adoption**
- ✓ **CIG Community**

- **CIG Release 2011 : CIG AddOn Support Packs**
- **CIG Platform & Portal Enhancements**
- **New Feature Innovations : Ariba Network Buy Side**
- **New Feature Innovations : Ariba Network Sell Side**
- **New Feature Innovations : Ariba Applications (Buying & Invoicing, Sourcing & Contracts)**
- **New Feature Innovations : Intelligent Enterprise Source To Pay Integration (IES S2P)**

# Overview



# Cloud integration strategy

**BUYERS**

**SUPPLIERS**

**CIG Add-ons**



**SAP Fieldglass**

**SAP IBP**

**SAP Concur**

**SAP S/4HANA MTE**

**Non-SAP ERP's (Future)**

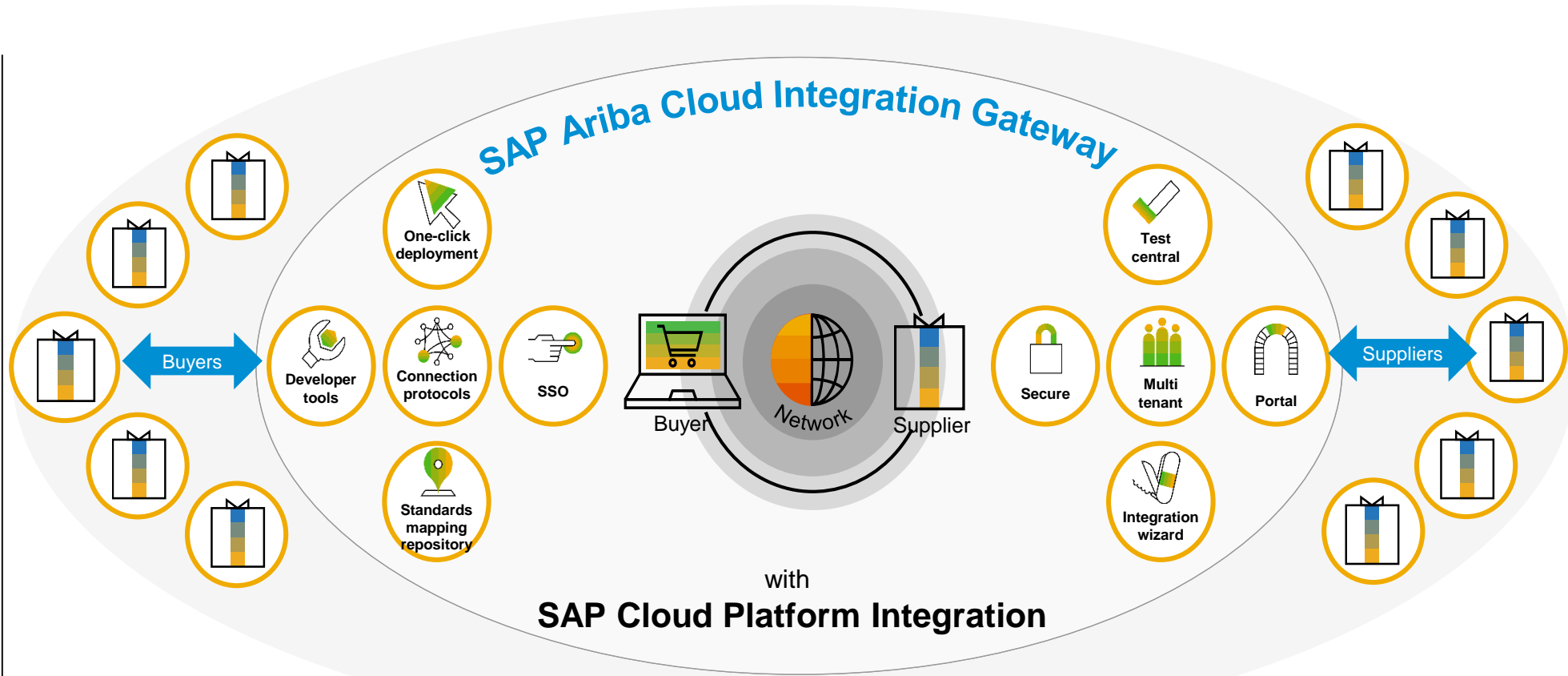

with  
**SAP Cloud Platform Integration**

- EDIFACT
- X12
- OAGIS
- GUSI
- EANCOM
- PIDX
- cXML

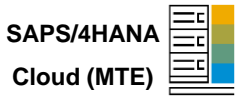

# Source To Pay Processes: End to End Integration via CI/IG

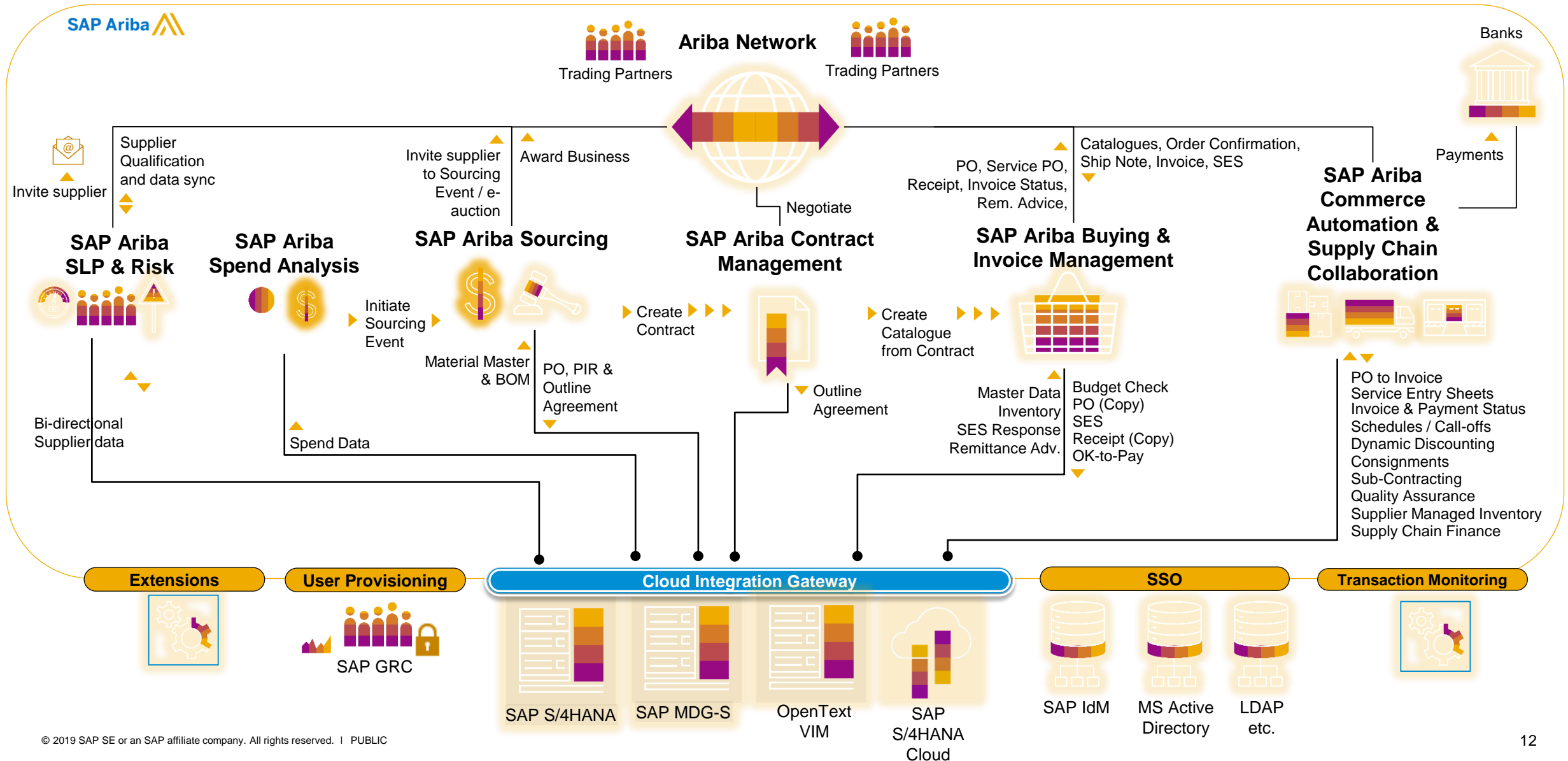

# Architecture

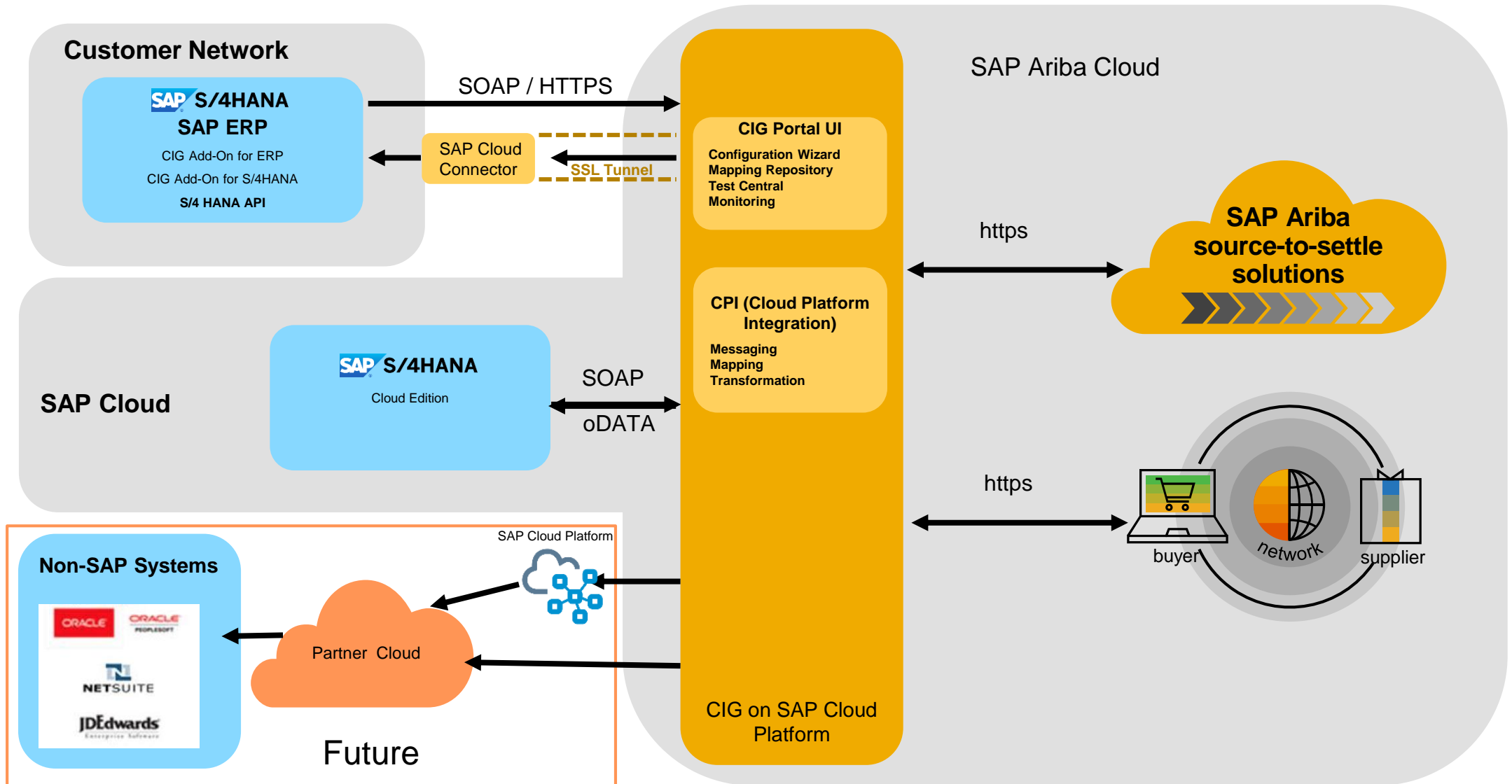

# Standard integrations **CIG – 233** (Q4 2020)

149 = SAP ERP and SAP S/4HANA

84 = Other Formats – Network Sell side

Ariba Applications	Sourcing	<b>Master</b> <b>22</b> <b>Sourcing and Contracts</b> Purchasing organization Purchasing groups Company code Payment Terms Plants Incoterms Material Master Material Master/Plant Material Groups	<b>Product Sourcing</b> Purchase Info Record Manufacturer Part Number Bill of Material Replication Bill of Material Confirmation	<b>Supplier Management</b> SLP outbound (pass-through) SLP inbound (pass-through)	<b>Sourcing – Retail</b> Article Master Characteristics Profile (Class) Merchandise Category Display Set Article/Site Generic Article Variant	<b>Transaction</b> <b>9</b> <b>Sourcing</b> RFQ to Quote request Quote Message Sourcing Award to PO Sourcing Award to Outline Agreement <b>cRFQ (Central RFQ)</b> <b>cSQ (Central Supplier Quotation)</b>	<b>Contracts</b> Contract Workspace to Outline Agreement Scheduling Agreement Central Contract	103								
	Procurement	<b>Master</b> <b>38</b> <b>Buying and Invoicing</b> Account categories Assets Asset Class Company codes Cost centers Cost center languages ERP commodity codes General ledger Internal orders Plant	Payment terms Purchase groups Tax codes WBS elements User data User group mapping Remittance locations Supplier data Supplier location Contracts	Company code internal order mapping Company code WBS element mapping Purchasing organization supplier combo Account category field status Plant to purchasing organization Currency conversion rates Fund management objects Purchasing organizations General ledger languages	Fund FM derive Earmarked Fund Functional Area Funds Center Commitment Item Budget Period FM Area Grant	<b>Transaction</b> <b>34</b> <b>Buying and Invoicing</b> Requisition via GB (Odata) Central Requisition via GB (Odata) Material PO Service PO Blanket/Limit PO Change PO Cancel PO Close PO Goods Receipt Service Entry Sheet Carbon Copy (CC) SES Cancel Service Entry Sheet Invoices (Ok-to-Pay) Non-PO Invoice (One Time) PO status Change PO status Import Requisitions	Asset Shell Receipt status Invoice status Remittances Catalog Syndication Inventory stock update Advance Payment requests Advance Payments Cancel Advance Payment Requisition Export Change Requisition Reservation Budget Check SES Response Expense report FI Invoice Cancel Invoice in ERP									
Ariba Network	Buy side	<b>46</b> <b>Commerce Automation</b> Standard Material PO Service PO Change PO Cancel PO Order Enquiry request Order Confirmation Inbound Ship Notice Outbound ASN Outbound Payment Remittance Inbound Remittance Advice Remittance Cancellation Inbound Receipt Outbound Receipt Service Entry Sheet Carbon Copy (CC) SES Service Entry Status update Cancel Service Entry Sheet Invoice (incl. Credit Memo) FI Invoice (incl. Credit Memo) Consignment Invoice Invoice status Carbon copy (CC) invoice Quote request Quote message Payment batch file Batch Managed PO Payment Receipt	<b>Discounting</b> Inbound Payment proposal Outbound Payment proposal	<b>Supply Chain Collaboration</b> Subcontract PO Multi-Tier Subcontract PO Consignment PO Component consumption Transfer movement (Product Activity) Order Confirmation Approval	<b>Forecast and SMI</b> Scheduling Agreement Forecast Demand (Product Activity) Inventory Levels (Product Activity) Product Replenishment Replenishment Order for SMI	<b>Quality Management</b> Quality Notification Quality Inspection Request Quality Inspection Result Quality Inspection Decision Quality Certificate QN Code (standard and custom)	<b>Sell side</b> <b>84</b> <b>X12 v4010</b> 810, 820, 204 214 824 (In & Out) 830 (Forecast) 830 (Commit) 832 842 (In & Out) 846 (In & Out) 850, 855, 856, 860 861 862 864 866 866 (MO/PO) 997 (In & Out)	<b>EDIFACT D01B</b> ORDERS ORDCHG DESADV INVOIC	<b>GS1 EANCOM 97</b> ORDERS ORDCHG DESADV INVOIC REMADV	<b>GS1 GUSI</b> MultiShipmentOrder DispatchAdvice ReplenishmentProposal ReplenishmentRequest ProductForecast GoodsRequirement ReceiptAdvice ConsumptionReport InventoryActivityorInventory Status	<b>SAP ERP &amp; S4 HANA Cloud</b> Sales Order Outbound Delivery Goods Issue (PGI) Billing Document	<b>EDIFACT D96A</b> ORDERS ORDCHG ORDERS INVOIC DESADV CONTRL RECADV INVRPT REMADV DELFOR DELJIT APERAK IFTMIN IFTSTA	<b>GS1 EANCOM 2002</b> ORDERS ORDRSP ORDCHG INVOIC DESADV REMADV	<b>OAGiS v9.2</b> ProcessPurchaseOrder (PO) AcknowledgePurchaseOrder NotifyShipment ProcessReceiveDelivery NotifyPlanningSchedule NotifyInventoryConsumption NotifyProductionOrder NotifyInventoryBalance ConfirmBOD	<b>PiDX v1.61</b> OrderRequest OrderChange OrderResponse Invoice InvoiceResponse Receipt ReceiptAcknowledgement Exception InvoiceResponseSESR AdvancedShipNotice	130

# Adoption Metrics

## OOTB Integration Touchpoints



**233**

Out-of-box between SAP ERP, S/4HANA,  
SAP Ariba Solutions and Suppliers  
(as of Q4/2020)

## Buyers Transacting in Production



**495**

Transacting in production on CIG  
30 Oct 2020

## Trading Partners in TEST Phase

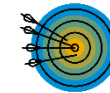

**900+ Buyers**  
**1700+ Suppliers**

New nodes and migration with various SAP  
Ariba solutions and SAP systems

## Processed Transactions



**135+** Millions

transactions processed on Buy & Sell side  
in Year: 2020

## Suppliers Transacting in Production



**1950+**

Across 8 data formats. 50% reduction in  
integration time.

## Globally Trained Resources



**1200+**

Trained resources across 5 global regions. And  
10+ CIG ready partners

# CIG Community

**SAP Ariba CIG Community** is the official user community of **SAP SE**. SAP software users, developers, consultants, mentors and students use the SAP Community Network to get help, share ideas, learn, innovate and connect with others

 **Connect, Collaborate & Contribute**

 **Learn > Network > Succeed**

 **Blog a Blog**

 **Ask questions**

<https://community.sap.com/topics/ariba-cloud-integration-gateway>

## SAP Ariba Cloud Integration Gateway

Welcome to SAP Ariba Cloud Integration Gateway (CIG) community! Join us to access expert content and stay up-to-date with the latest announcements and features. Ask our experts a question, engage with other community members, and follow latest blogs.

### Featured Content



#### SAP Ariba Cloud Integration Gateway At-A-Glance

SAP Ariba Cloud Integration Gateway, enabled by the SAP Cloud Platform Integration service, transforms the integration process by making it simple to connect your trading partners, SAP Ariba applications, and backend systems such as SAP ERP and SAP S/4HANA\* for touch-less, end-to-end transactions.

[Watch Video \(3 Minutes\)](#)



#### SAP Ariba Cloud Integration Gateway : State of the Union

Out of Box Standard Integrations helping SAP Ariba Customers to start transacting between SAP ERP and SAP Ariba solutions in fraction of traditional integration timeline

[State of the Union](#)



#### SAP Ariba CIG Road Map for Buyers and Suppliers

Describes the new features for SAP Ariba Cloud Integration Gateway release.

[View the road map](#)



#### Announcements

Follow all the latest happenings with Ariba Cloud Integration Gateway

[CIG January 2020 Monthly Release Deployed on 30th January 2020](#)

[CIG AddOn Quarterly Q4 Released on 13th Dec. 2019](#)

### Expert Content



#### SAP Ariba CIG Mapping Tool

Mapping tool enables CIG customers to customize standard mappings to meet specific business needs

[Mapping Tool](#)



#### SAP Ariba CIG Co-Existence

Business use case and configuration to run both CIG and Business Suite AddOn Together (Co-existence) for SAP Ariba Integration with SAP ERP / S4 HANA helping customers to manage migration to CIG in a phased approach

[CIG Co-Existence](#)



# Call for Action

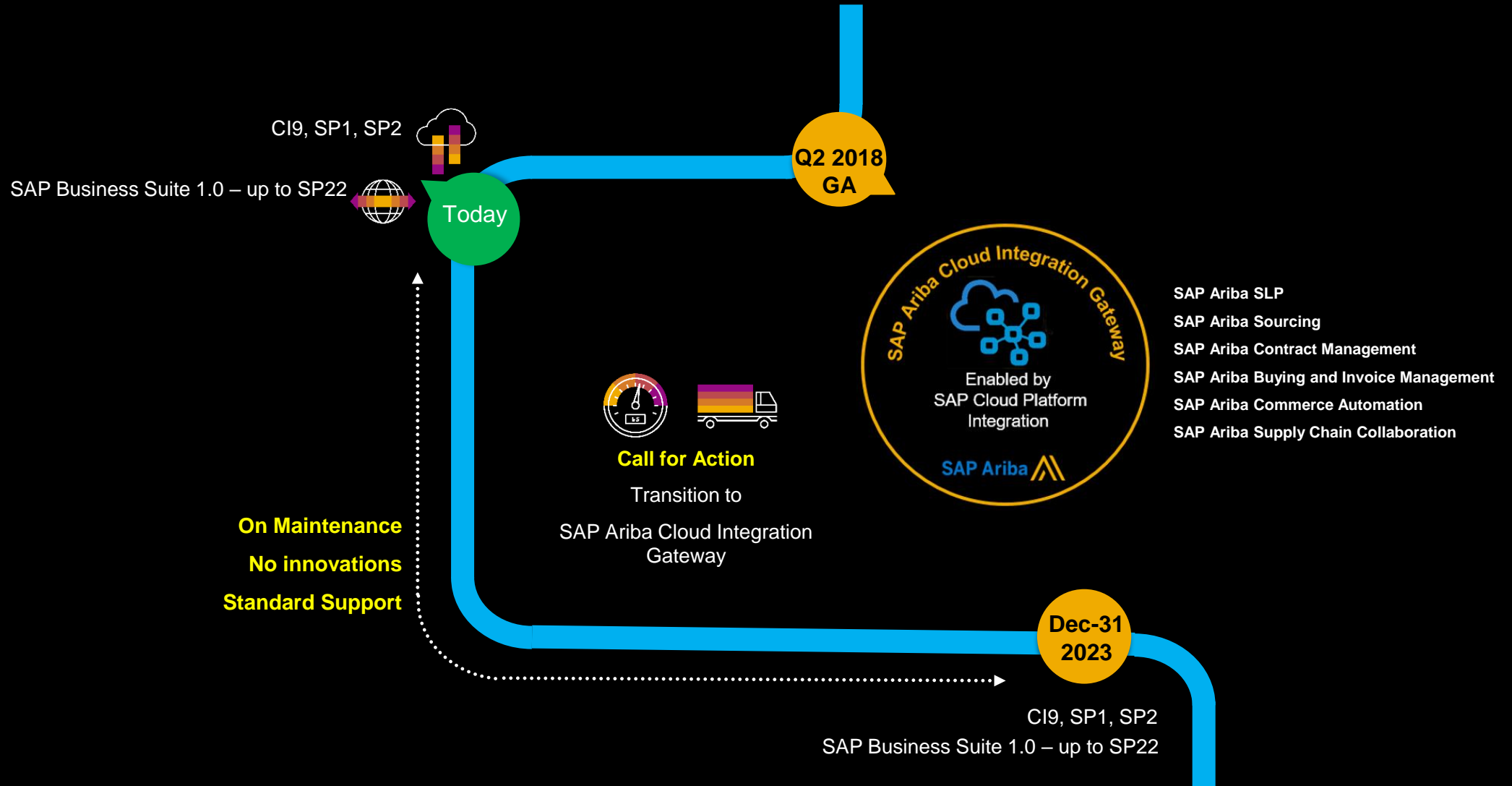

# **CIG Release & CIG AddOn Support Packs**



# CIG AddOn Components & Support Packs

CIG Buyer AddOn for SAP ERP	
ABAP component	Support Pack
ARBCI1 100	SP11
ARBCI2 100	SP9
ARBCIGR 100	SP1

CIG Supplier AddOn for SAP ERP	
ABAP component	Support Pack
ARBCIS 100	SP2

CIG Buyer AddOn for S/4 HANA	
ABAP component	Support Pack
ARBCI1 10S	SP11
ARBCI2 10S	SP9
ARBCIGR 10S	SP1

- **CIG AddOn Certification for S/4 HANA 2020**
  - **IG-17846** Certification of SAP Ariba Cloud Integration Gateway with SAP S/4HANA 2020
  - **IG-20608** Enhancement to event linkages for enabling the integration of SAP ERP or SAP S/4HANA with SAP Ariba solutions

# **CIG Platform & Portal Enhancements**



# CIG High Availability Architecture Enhancements

## Platform

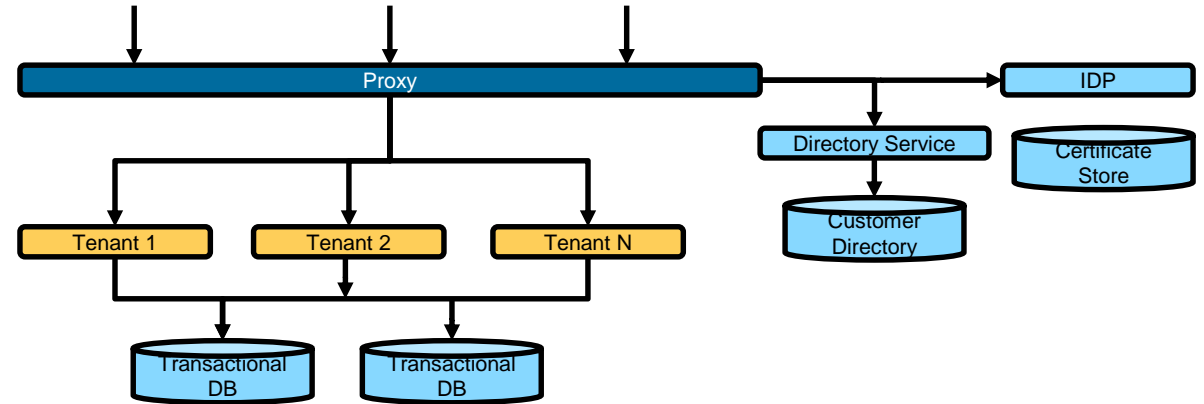
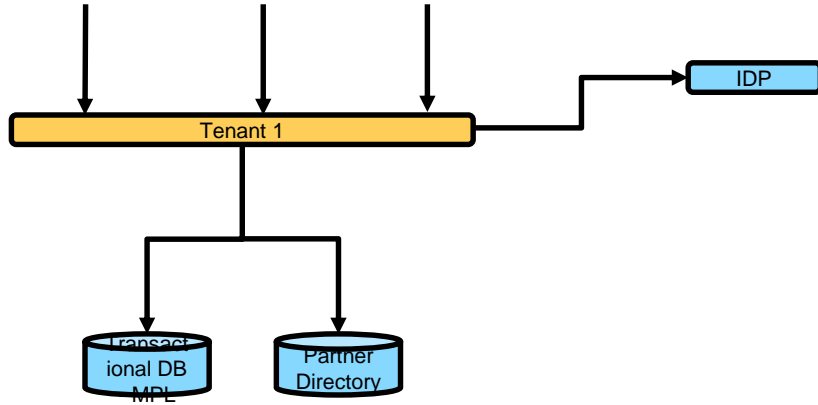

## Portal

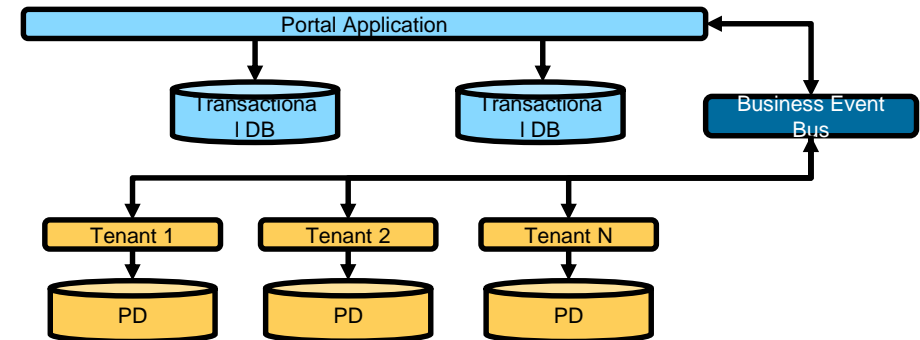
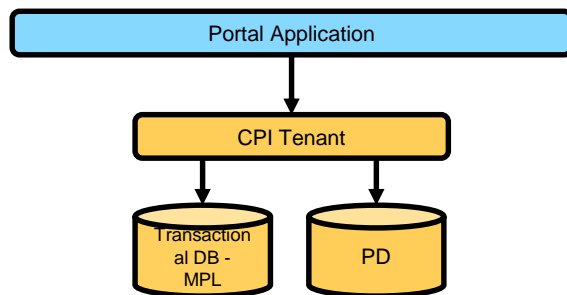

# CIG High Availability Architecture Enhancements

## Platform

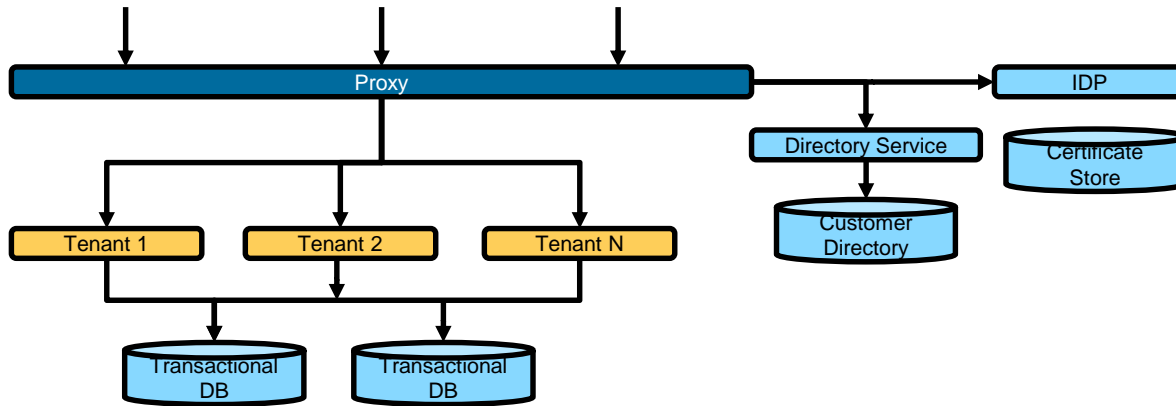

✓ ~100% availability

- Diversify the solution and remove CIG from a single point of failure
- ZERO downtime on software updates

✓ Scalable

- Allow to increase capacity on demand based on performance or issues

## Portal

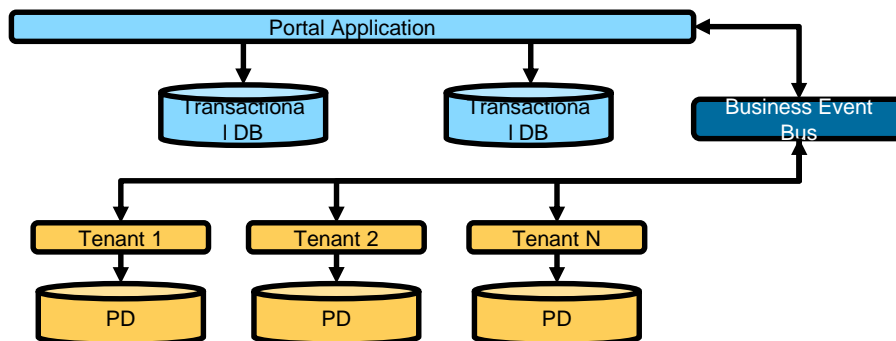

✓ Auto Load distribution

- Distribute the load of the platform in multiple CPI instances and DBs

✓ Smart Monitoring

- Monitor the components on different levels
- Allow proxy to add or remove instances

# New Feature Innovations: Ariba Network Buy Side

- Commerce Automation
- Supply Chain Collaboration (SCC)



# New Feature Innovations: Ariba Network Buy Side

- **IG-16312**            **Enhancements to the Order Request cXML transaction document**
- **IG-19847**            **Enhancements to the product activity message for supplier managed inventory and forecast collaboration**
- **IG-19268**            **Enhancements to integration for quality notifications**
- **IG-14435**            **Integration to support sending work order-based purchase orders to Ariba Network**
  
- **IG-19654**            Enhancement to the integration of service entry sheet response from SAP ERP or SAP S/4HANA to Ariba Network and SAP Ariba Procurement solutions
  - ✓ SES response along with Long Text when SES is deleted
  
- **IG-18020**            Support to standardize invoice IDs in ERP-initiated invoices to Ariba Network and the subsequent transactions
  - ✓ Standardized approach to send Invoice ID in ERP initiated Invoice and subsequent transactions such as Invoice Status Update, Payment Remittance, Payment Proposal



# IG-16312: Enhancements to the OrderRequest cXML transaction document

## Customer Challenge

- Though SAP ERP and S/4 HANA supports multiple texts at Header and Item Level for Purchase Order, Scheduling Agreement, Ariba Network supported only single comment hence multiple texts were concatenated and sent to Ariba Network

## Solution

- Order Request cXML has been enhanced to support multiple comments at both Header and Item level
- CIG provides cross-reference parameter to configure which specific Text IDs are sent to Ariba Network and in what sequence
- Each Text from PO / SA Header and Item are sent as separate comment, each identified by Text Type
- Additional enhancements are delivered with this feature for :
  - unlimitedDelivery for Material items is sent to Ariba Network to allow unlimited quantities during ship notice processing in Ariba Network
  - isKanban indicator for material items for SAP Ariba Supply Chain Collaboration for Buyers
  - isItemChanged attribute to indicate changes to line items (requires a BAdI implementation by customers)

## Key Benefits

- Enhanced collaboration for Buyers and Suppliers

# IG-16312: Enhancements to the Order Request cXML transaction document

## CIG Cross Reference Parameters

TEST Environment (SystemId: Q8JCLNT002)

HeaderTextID SAR:	L02,L03,L01,L04,L05,L...
Ord Enqr DefaultLang:	DE
PO HeaderTextID:	F08,F09,F10,F11,F12,F13
SA LineTextID SAR:	L01,L03,L02,L04,L05
Sample1:	
PO LineTextID:	5,ZDVD,F01,F04,F03,F02
SendManufacturerName:	X

PROD Environment (SystemId: Q8JCLNT002)

HeaderTextID SAR:	L02,L03,L01,L04,L05,L...
Ord Enqr DefaultLang:	DE
PO HeaderTextID:	F02,F01,F03,F04,F05, ...
SA LineTextID SAR:	L01,L03,L02,L04,L05
Sample1:	
PO LineTextID:	F01,FB01,FB15,ZDVD, ...
SendManufacturerName:	X
Use same values:	<input checked="" type="checkbox"/>

I

# IG-16312: Enhancements to the Order Request cXML transaction document

Create Order Confirmation ▼ Create Ship Notice Create Invoice ▼ Create Quality Notification ↓

Order Detail Order History

From: SAP ARIBA -1  
234-123456  
10243 Berlin  
Berlin  
Germany  
Phone: + ( ) 12345678 1234  
Fax: + ( ) 23344557788 123456

To: t1q8jqis - TEST  
jUnitDummy, Address 1,  
!@\$%^&\*(), Pueblacity, Address 2,  
Mexico city Municipality,  
12345 Puebla  
Aguascalientes  
Mexico  
Phone: +1 (650) 3902788  
Fax: +1 (650) 3902788  
Email: t1q8jqis@sap.com

Purchase Order  
(New)  
4500044668  
Amount: 2,000.00 EUR  
Version: 1

Payment Terms ⓘ  
5.000% 5  
3.000% 10  
0.000% 30  
within 5 days 5 % cash discount within 10 days 3 % cash discount within 30 days Due net

Routing Statu  
External Document Typ

Comments

Header note: Header note maintained as below  
Alpha numeric abc\_1234567890  
spl. char: "cost @ 999\$ = #value & (check)"

Header text: Header text maintained as below  
Instructions to Vendor:  
Please adhere to T&C

Pricing types: Pricing types maintained as below  
Purchase order  
When a buying organization requests products or services through its SAP ERP system, the Ariba Network Adap ... [View more »](#)

Deadlines: Deadlines maintained as below  
Vendor to adhere to time deadlines

Terms of delivery: Terms of delivery maintained as below  
There is no Where-Used-List for this "logic" and if you do an F1 on the CALL ' ...statement you will see that the documentat ... [View more »](#)

[More\(8\) »](#)

## Purchase Order Header Texts in Ariba Network

# IG-16312: Enhancements to the Order Request cXML transaction document

Line #	Part #	Customer Part #	Type	Return	Revision Level	Qty (Unit)	Need By	Unit Price	Subtotal	Customer Location
10	469	261	Material			10.000 (EA)	8 Jun 2020	100.00 EUR	1,000.00 EUR	

[Summary](#)

Description: PAM Test central material

#### Status

10.000 Unconfirmed

#### Control Keys

Order Confirmation: not allowed

Ship Notice: not allowed

Service Entry Sheet: not allowed Unit Price Editable:

Invoice: is not ERS

Invoice Verification Type: goods receipt

#### Comments

Item text:	Item text maintained as below Instructions to Vendor:  Please adhere to T&C
Info record PO text:	Info record PO text maintained as below Alpha numeric abc_1234567890 spl. char: "cost @ 999\$ = #value & (check)"
Delivery text:	delivery text maintained as below There is no Where-Used-List for this "logic" and if you do an F1 on the CALL ' ...statement you will see that the documentation ... <a href="#">View more »</a>
Material PO text:	material PO text maintained as below When a buying organization requests products or services through its SAP ERP system, the Ariba Network Adapter for SAP Net ... <a href="#">View more »</a>
Info record note:	Info record note

[More\(1\) »](#)

## Purchase Order Item Texts in Ariba Network

# IG-19847: Enhancements to the product activity message for supplier managed inventory and forecast collaboration

## Customer Challenge

- Demand generated from Stock Transfer Requisitions was not considered while sending Gross demand for Supplier Managed Inventory to Ariba Network
- Buyer was not able to restrict sending SMI & Forecast data based on Plant specific Material status

## Solution

- Demand from Stock transfer requisitions is selected and included in Gross Demand while sending SMI data to Ariba Network
- Additional selection criteria is provided for SMI & Forecast reports to limit selection of material data based on Plant specific Material status

## Key Benefits

- Additional flexibility for buyers to select material demand and inventory data based on material status
- Enhanced control on planning collaboration

# IG-19847: Enhancements to the product activity message for supplier managed inventory and forecast collaboration

**Extract Stock/Demand for SMI Product Activity Message**

General Parameters

Plant	<input type="text"/>	to	<input type="text"/>
MRP Area	<input type="text"/>	to	<input type="text"/>
Material	<input checked="" type="checkbox"/> <input type="text"/>	to	<input type="text"/>
MRP Type	<input type="text"/>	to	<input type="text"/>
MRP Controller	<input type="text"/>	to	<input type="text"/>
MRP Group	<input type="text"/>	to	<input type="text"/>
Purchasing Group	<input type="text"/>	to	<input type="text"/>
Plant-sp.matl status	<input type="text"/>	to	<input type="text"/>

**Extract Forecast Product Activity Message**

General Parameters

Plant	<input type="text"/>	to	<input type="text"/>
MRP Area	<input type="text"/>	to	<input type="text"/>
Material	<input checked="" type="checkbox"/> <input type="text"/>	to	<input type="text"/>
MRP Type	<input type="text"/>	to	<input type="text"/>
MRP Controller	<input type="text"/>	to	<input type="text"/>
MRP Group	<input type="text"/>	to	<input type="text"/>
Purchasing Group	<input type="text"/>	to	<input type="text"/>
Plant-sp.matl status	<input type="text"/>	to	<input type="text"/>

**Extract Stock/Demand for SMI Product Activity Message**

Stock Category

Consignment Stock       Own Stock

Unrestricted Use Stock  
 Stock in Quality Inspection  
 Blocked Stock  
 Zero Stock

Additional Stock Type

Subcontract. Stock at Vendor

Additional Stock Data

Required Maximum Quantity       Required Minimum Quantity       Increment Quantity  
 Batch

Unit of Measure

Order Unit Of Measure

Demand

Time Period

Date  to   
 Requirement Date

Gross Demand

Planned Independent Req.  
 Dependent Demand  
 Sales Order  
 Dependent Reservation  
 Reservation  
 Stock Transfer Requisition

# IG-14435: Integration to support sending work order-based purchase orders to Ariba Network

## Customer Challenge

- Purchase Orders generated from Plant Maintenance Work Orders were not integrated with Ariba Network

## Solution

- Purchase Orders generated from Plant Maintenance Work Orders are integrated with Ariba Network sending workorder information and Equipment ID associated with the Work Order
- Work Order information is sent at accounting level whereas Equipment ID is sent at PO Item level

## Key Benefits

- Enhanced collaboration for Buyers and Suppliers specific to Plant Maintenance service orders

# IG-14435: Integration to support sending work order-based purchase orders to Ariba Network

## Line Items

Line #	Part #	Customer Part #	Type	Return	Revision Level	Qty (Unit)	Need By	Unit Price	Subtotal	Customer I
10			Material			10.000 (EA)	18 Feb 2020	1,000.00 EUR	10,000.00 EUR	

Description: Electric wires

### Status

10.000 Unconfirmed

### Control Keys

Order Confirmation: not allowed

Ship Notice: not allowed

Invoice: is not ERS

Invoice Verification Type: goods receipt

### Accounting

GeneralLedger	ID	400000
WorkOrder	ID	4000748
PERCENTAGE	PERCENTAGE	100.00

## Schedule Lines

Schedule Line #	Delivery Date	Ship Date	Quantity (Unit)
1	18 Feb 2020 12:00 PM IST		10.000 (EA)



# IG-19268 : Enhancements to integration for quality notifications

## Customer Challenge

- Existing Quality Notification integration did not support certain use cases and ERP buyers needed to implement customization via BADIs

## Solution

- Configuration option to
  - restrict sending Quality Notifications based on certain system status / user status
  - prevent sending certain Tasks / Activities that are considered internal to buyer's organization
  - enable Quality Notification integration for a specific suppliers and Company Code
- Support integration of Quality Notifications
  - with free text material (without reference to a material master ID)
  - with serial numbers in the header from ERP to Ariba Network and vice versa
  - with item material and item batch from ERP to Ariba Network and vice versa
- Provided a new method - user-triggered action - to send quality notification from ERP
- New event linkage configuration is provided to trigger QN integration based on events INPROCESS / APPROVED
- Many more additional functionality enhancements are delivered (Refer to feature documentation)

## Key Benefits

- Enhanced control for Quality Notification integration with standard out of the box integration

# IG-19268 : Enhancements to integration for quality notifications

## Prevent sending Quality Notification to Ariba Network based on System status and/or User Status



Parameters - Notification Type			
Modify More Info			
Variable Name	Field Name	Num.	Low
QNTYPE_ARB		0000	Q7
QNTYPE_ERP		0000	Q6
QN_DISABLED		0000	
QN_STAT_FILTER		0000	I0525
QN_STAT_FILTER		0001	I0527
QN_STAT_FILTER		0002	E0006

I0527	APRF	Approval: Refused
I0525	APRQ	Approval: Required

**Display logs**

Technical Information

Date/Time/User	Num.	External ID	Object text	Subobject Text	Transacti.	Program	Mode	Log number
> 04.11.2020 06:53:44 WF-BA	1	000200002120	ARBCIG_NETW_	QN_MESSAGE		SAPMSSY1	Dialog pro_	000000000000002528_
> 04.11.2020 06:54:24 WF-BA	1	000200002121	ARBCIG_NETW_	QN_MESSAGE		SAPMSSY1	Dialog pro_	000000000000002528_
> 04.11.2020 17:09:53 VALLUF	1	000200001490	ARBCIG_NETW_	QN_MESSAGE	QM02	SAPLIQS0	Dialog pro_	000000000000002528_

0 0 1 0

Ty\_ Message Text  
 ▲ QN 000200001490 not passed to Ariba Network because of wrong status

In addition, new **BADI** ARBCIG\_QN\_FILTER is provided to alter / customize the functionality, for example, based on QN type or Creation date

# IG-19268 : Enhancements to integration for quality notifications

## Prevent sending specific QN Tasks / Activities to Ariba Network

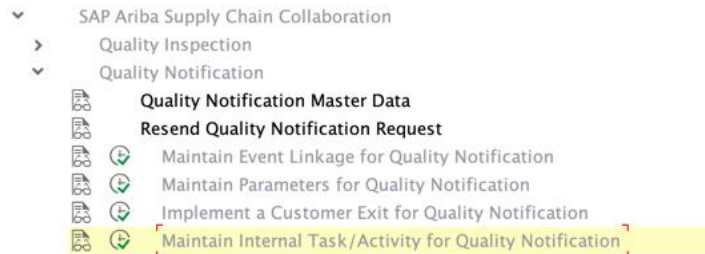

Change View "Maintain Internal Task/Activity for Quality Notification"

New Entries

Cat.Prof.	Catalog	Code group	Code
QM0000001		QM-G2	0007
QM00000018		QM-G2	0006

Tasks and Activities configured here are also excluded in QN Master data export

In addition, new **BADI** ARBCIG\_QN\_FILTER is provided to alter / customize the functionality, for example, based on QN type or Creation date

# IG-19268 : Enhancements to integration for quality notifications

## Enable QN Collaboration for specific Suppliers and Company Codes

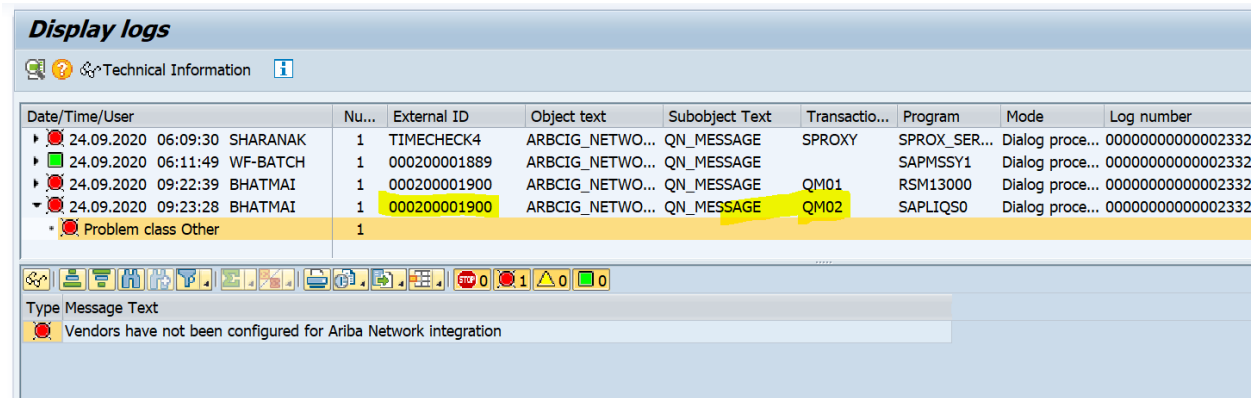
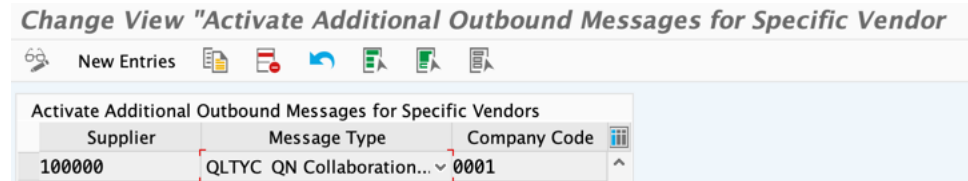
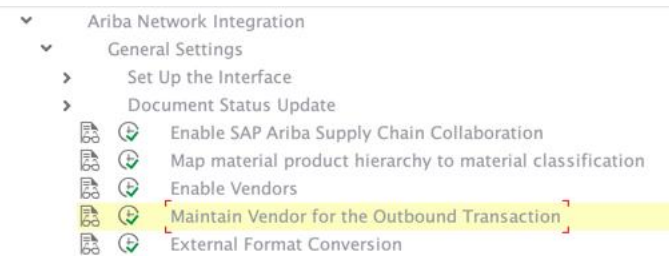

# IG-19268 : Enhancements to integration for quality notifications

## Enable QN Collaboration for specific Suppliers and Company Codes: Upload program

### Transaction: ARBCIG\_AN\_VENDOR\_UPL

*Mass Upload program to load data in Ariba Vendor and Outbound table*



**File Selection**

Select csv filename to download/upload

Select the File

\*\*\* Upload only csv file format (\*.csv)  
\*\*\* CSV file should have first line as column headers.  
\*\*\* Use Excel Format Cell options to keep leading zeroes in numeric fields  
\*\*\*Maintain value X under columns PROA & QLTYC to upload in OB Vendor table  
\*\*\*Download the file in XLS format

**Upload and Download options**

Upload the File  Download the File

**Select option to Save or Delete table entries**

Save Table entries  
 Delete Table entries

**Test mode to Display entries**

Test Mode

# IG-19268 : Enhancements to integration for quality notifications



User Triggered Transaction to send / resend Quality Notification to Ariba Network

Transaction: ARBCIG\_QLTY\_NOITF

*Resend Quality Notification to Ariba Network*



**Quality Notification**

Notification key   to  

**Resend Quality Notification**

Resend QN created

Resend QN changed

# IG-19268 : Enhancements to integration for quality notifications

## Quality Notification with Serial Number as Reference Object

**Display Notification: Complnt f. Cus Ariba**

Notification: 200000104 | Q6 Complnt f. Cus Ariba

Notific. Status: OSNO NOTE OSTs

Description: DESCRIPTION

Reference Objects | Problem Details | Items | Actions | Activities

Reference Documents

Referen. Notif.		Reference No.	
Purchasing Doc.		0	
Material Doc.		0	

Reference Object

Material	000000000000001788			
Description	SUBCON-RAWMAT3			
Revision Level		Plant for Mat.	0001	Plant
Serial Number	101	Batch		

Quality notification: 200000104

Detail | Defect (1) | Partner info | History | Print | Export cXML | Communication

Status: New

Customer	t1q8jb9 - TEST	Supplier deviation no.	200000104
Supplier part no.		Customer deviation no.	200000104
Customer part no.	1788	Purchase order no.	
Customer location	0001 - MDG Plant 0001	Purchase order line item no.	
Quality notification type	Q6 - Complnt f. Cus Ariba	Ship notice no.	
Revision level		Ship notice line item no.	
Priority	Medium	Subcontracting component?	No
Category	\$\$OSS001 - SAP Notifications	Customer batch	
Subcategory	\$\$01 - R/3 problem notification	Supplier batch	
Malfunction start date		Serial no.	101

Description: DESCRIPTION

Created by: BHATMAI

Thursday, October 1, 2020, 9:45 AM

Reason code

Comments: 01.10.2020 08:06:53 CET (BHATMAI) comm

# IG-19268 : Enhancements to integration for quality notifications

## Quality Notification with Batch & Supplier Batch as Reference Object in QN Header

Notification: %0000000001 Q6 Complnt f. Cus Ariba BATCHH

Notific. Status: OSNO NOTE OSTs

Description: DESCRIPTION

Reference Objects | Problem Details | Items | Actions | Activities

Reference Documents

Reference notif		Reference no.	BATCHH
Purchasing Doc.			
Material Doc.			

Reference object

Material	39800	balatest	
Revision Level		Plant for mat.	0001 Werk 0001_te
Serial Number		Batch	267
Device data		Prod. Date	
Vendor Mat. No.		Vendor Batch	3333
MDN Material			

Quality notification: BATCHH

Detail | Defect (1) | Partner info | History

Status: New

Customer	t1q8jb9 - TEST	Supplier deviation no.	BATCHH
Supplier part no.		Customer deviation no.	200001956
Customer part no.	39800 - Line 20	Purchase order no.	
Customer location	0001 - MDG Plant 0001	Purchase order line item no.	
Quality notification type	Q6 - Complnt f. Cus Ariba	Ship notice no.	
Revision level		Ship notice line item no.	
Priority	Low	Subcontracting component?	No
Category	\$\$OSS001 - SAP Notifications	Customer batch	267
Subcategory	\$\$01 - R/3 problem notification	Supplier batch	3333



# IG-19268 : Enhancements to integration for quality notifications

## Quality Notification with Batch at QN Item (One Batch per Item)

Notification: 200000118, Q6 Complnt f. Cus Ariba, OSNO NOTE OSTs, DESCRIPTION

Requires activation of business function, OPS\_QM\_EXTENSION

No.	Code Group	Defe...	Defect loc.	Code Group	Defe...	Defect type	Assembly
1				QM-M	1	Dimension	000000000000001786

Description

---

Cause (1)

---

Additional Impacted Batches (1)

Report the same issues for multiple batches or parts.

	Supplier part no.	Customer part no.	Customer location	Customer batch	Supplier batch
0001		000000000000001786 - SUBCON-RAWMAT1		BATCH1	

# **New Feature Innovations: Ariba Network Sell Side**



# New Feature Innovations: Ariba Network Sell Side

- **IG-18421**                    **Including buyer's VAT ID in invoices created on the supplier's ERP system**
  - ✓ Buyer and Supplier VATIDs sent on Invoice from AddOn.
- **IG-20875**                    **ER - EDI limitation on Decimals (ASCx12, EDIFACT and EANCOM)**
  - ✓ Due to EDI limitation (ASCx12, EDIFACT and EANCOM) CIG will truncate the value to its corresponding limitation because AN cXML support up to 15 decimals.
- **IG-12033**                    **EANCOM INVOIC D96A to cXML InvoiceDetailRequest - Parity update to cXML 1.2.043**
  - ✓ The qualifier "ACE" has to be added in the codelist
  - ✓ And over 90 new mapping segments will be covered in this parity update
- **IG-12034**                    **cXML OrderRequest to EANCOM ORDERS D96A - Parity update to cXML 1.2.043**
  - ✓ And over 70 new mapping segments will be covered in this parity update
- **IG-12035**                    **cXML OrderRequest to EANCOM ORDCHG D96A - Parity update to cXML 1.2.043**
  - ✓ And over 70 new mapping segments will be covered in this parity update
- **IG-12031**                    **EDIFACT INVOIC D01B to cXML InvoiceDetailRequest - Parity update to cXML 1.2.043**
  - ✓ And over 70 new mapping segments will be covered in this parity update

# New Feature Innovations: Ariba Applications

- Buying & Invoicing
- Sourcing
- Contracts



# New Feature Innovations: Ariba Applications

- **IG-20805**            **Support for importing the input tax code and the withholding tax code master data from SAP ERP or SAP S/4HANA to SAP Ariba Procurement solutions**
  
- **IG-21022**            **Enhancement to the interface to extract user master data from SAP ERP to master data native interface (MDNI)**
  
- **IG-17025**            **Support for integrating scheduling agreements between SAP Ariba Sourcing and SAP ERP or SAP S/4HANA**
  
- **IG-14732**            **Integration to support sending production facility information between SAP Ariba Contracts and SAP ERP**
  - ✓ Include production facility information in the contract workspace. Specify information about the production facility associated with the supplier. This contract is published to SAP ERP or SAP S/4HANA as a contract
  - ✓ BADI to support change Partner Functions
  - ✓ Configure partner determination procedure to process production facility information
  - ✓ Enable SAP Ariba Supplier Lifecycle and Performance (SLP)

# IG-20805 :Exporting the input tax code and the withholding tax code master data to SAP Ariba Procurement solutions

## Customer Challenge

- Importing of Withholding Tax codes from SAP ERP to Ariba Procurement systems is not supported. Transactions like invoice support Withholding Tax, customers had to manually import the WHT codes.
- Earlier tax code data model was replaced with a newer data model and previous tax code import event is deprecated. Need to support the new import event and data model.

## Solution

- Existing Master data extract program is enhanced to provide export of:
  - ✓ Input tax codes and
  - ✓ Withholding tax code
- Using the import new events for Tax code:
  - ✓ Import Tax code, Import Tax component, Import Tax types and Import Tax type mapping.
  - ✓ Out of the box integration is provided for Tax code and Tax component events.
  - ✓ Customers have to manually create and upload for Tax type and Tax type mapping.
- Full load only.

## Key Benefits

- New option to automatic extract of WHT and Input tax Codes, in addition to older tax code export.
- Supports new import event and tax code master data, thereby reducing manual import of tax codes

# IG-20805 :Exporting the input tax code and the withholding tax code master data

## Transaction FTXP: Input Tax Code

**Maintain Tax Code: Tax Rates**

Properties Tax accounts Deactivate line

Country Key: DE Germany  
 Tax Code: 1Y New Tax for DE  
 Procedure: TAXD  
 Tax type: V Input tax

**Percentage rates**

Tax Type	Acct Key	Tax Percent. Rate	Level	From Lvl	Cond. Type
Base Amount			100	0	BASB
Output Tax	MWS	5,000	110	100	MWAS
Input tax	VST	3,000	120	100	MWVS
Travel Expenses (%)	VST		130	100	MWRK
Non-deduct.Input Tax	NVP	2,000	140	100	MWVN
Non-deduct.Input Tax	NVV		150	100	MWVZ
Acquisition Tax Cred	ESA		200	100	NLXA
Acquisition Tax Deb.	ESE		210	200	NLXV
SD Tax	MWS		220	200	GS01

## Input Tax Code w Jurisdiction

**Maintain Tax Code: Tax Rates**

Properties Tax accounts Deactivate line Levels Periods

Country Key: US USA  
 Tax Code: 2Y New tax for US  
 Procedure: TAXUSJ  
 Tax Jurisdiction: 101110001 Sample entry for jurisdiction at city level  
 Valid from: 23.09.2020

**Percentage rates**

Tax Type	Acct Key	Tax Percent. Rate	Jurisdiction Cd	Name
Base Amount				
Subtotal				
Distributed to G/L				
A/P Sales Tax 1 Inv.	NVV	5,000	10000000	Sample entry for j-
A/P Sales Tax 2 Inv.	NVV	4,000	101110000	Sample entry for j-
A/P Sales Tax 3 Inv.	NVV	1,000	101110001	Sample entry for j-
A/P Sales Tax 4 Inv.	NVV			
Expensed				
A/P Sales Tax 1 Exp.	VS1	4,000	10000000	Sample entry for j-
A/P Sales Tax 2 Exp.	VS2	3,000	101110000	Sample entry for j-
A/P Sales Tax 3 Exp.	VS3	1,000	101110001	Sample entry for j-
A/P Sales Tax 4 Exp.	VS4			
Self-assessment				
A/P Sales Tax 1 Use	MW1	3,000	10000000	Sample entry for j-
A/P Sales Tax 2 Use	MW2	2,000	101110000	Sample entry for j-
A/P Sales Tax 3 Use	MW3	1,000	101110001	Sample entry for j-
A/P Sales Tax 4 Use	MW4			
Accrued				
A/R Sales Tax 1	MW1	2,000	10000000	Sample entry for j-
A/R Sales Tax 2	MW2	1,000	101110000	Sample entry for j-
A/R Sales Tax 3	MW3	1,000	101110001	Sample entry for j-
A/R Sales Tax 4	MW4			

# IG-20805 :Exporting the input tax code and the withholding tax code master data

## Withholding Tax Code Config.

Implementation Guide Edit Goto Additional Information Utilities System

Display IMG

Existing BC Sets BC Sets for Activity Activated BC

Structure

- Financial Accounting (New)
  - Financial Accounting Global Settings (New)
    - Ledgers
    - Global Parameters for Company Code
    - Document
    - Tax on Sales/Purchases
    - Withholding Tax
      - Withholding Tax
      - Extended Withholding Tax
        - Basic Settings
        - Calculation
          - Withholding Tax Type **1**
            - Define Withholding Tax Type for Invoice Posting
            - Define Withholding Tax Type for Payment Posting
            - Define Exchange Rate Type for Withholding Tax Type
            - Define Rounding Rule for Withholding Tax Type
            - Assign Condition Type to Withholding Tax Type
          - Withholding Tax Code **3**
            - Define Withholding Tax Codes
            - Define Formulas for Calculating Withholding Tax
          - Withholding Tax Base Amount
          - Minimum and Maximum Amounts
          - Argentina
          - Brazil
          - Colombia
          - India
          - Mexico
          - Great Britain
        - Company Code **2**
          - Assign Withholding Tax Types to Company Codes
          - Activate Extended Withholding Tax
        - Posting
        - Report
        - Generic Withholding Tax Reporting
        - Withholding Tax Changeover

## Withholding Tax Code details

Table View Edit Goto Selection Utilities System Help

Change View "Withholding tax code": Details

New Entries

Country DE Germany

General data	
Withheld tax type	3Y
W/tax code	3Y
Description	assigned to 3Y

Base amount		Postings	
Percentage subject to tax	100,00 %	Post.indic.	1

Calculation		Reporting information	
With/tax rate	4,0000 %	Region	
With/tax rate (fraction)	/	Prov.tax code	
<input type="checkbox"/> W.tax form.		Income type	

## Tax Type Category

Tax Type	Category
Input Tax	02
Withholding Tax	64



# IG-20805 :Exporting the input tax code and the withholding tax code master data

## Report: ARBCIG\_MASTER\_DATA\_EXPORT

Program Edit Goto System Help

Export All Master Data Required For On-Demand Application

Execution Mode

Test Run

Solution

SAP Ariba Procurement      SAP Ariba Strategic Sourcing

Procure-to-Pay       Sourcing and Contracts

Procure-to-Order

Load Option

Full Load       Incremental Load

Configuration

Encoding to be used      UTF-8

Variant

Partition

FPC Enabled

Choose Master Data for Export

Organizational Data

Plant       CompanyCode       PurchaseOrg

PlantPurchaseOrg       PurchaseGroup       Storage Location

Accounting Data

CostCenter       InternalOrder       GeneralLedger

WBS\_Element       Asset       Asset Class

Cross-application Configuration Data

AccountCategory       AccCategoryFieldStatus       ERPCommodityCode

CurrencyConversion       TaxCode       Input and Withholding TaxCode

Payment Terms

## Exported Files:

List Edit Goto System Help

Export All Master Data Required For On-Demand Application

Folder where the Master Data are Exported /tmp/processed20200923095336

Summary - Full Load - Test Run

Event	Type	Message
Tax Component	I	509 record(s) extracted
Tax Code Details	I	509 record(s) extracted
Tax Code Header	I	270 record(s) extracted

TaxCodeDetails

Sequence	Component	AppliedOn	MWSKZ	LAND1	BUKRS	ZZSTUN2	ZZSTUNR
AY	3Y3Y0001	BaseAmount	3Y	DE	1	0	0
A	1YDEMNAS	BaseAmount	1Y	DE		0	110
A	2YUSJP1100000000	BaseAmount	2Y	US		0	210
B	1YDEMWVS	BaseAmount	1Y	DE		0	120
B	2YUSJP2101110000	BaseAmount	2Y	US		0	220
C	2YUSJP3101110001	BaseAmount	2Y	US		0	230
D	1YDEMWVN	BaseAmount	1Y	DE		0	140
E	2YUSJP1E100000000	BaseAmount	2Y	US		0	310
F	2YUSJP2E101110000	BaseAmount	2Y	US		0	320
G	2YUSJP3E101110001	BaseAmount	2Y	US		0	330
I	2YUSJP1U100000000	A	2Y	US		0	410
J	2YUSJP2U101110000	A	2Y	US		0	420
K	2YUSJP3U101110001	A	2Y	US		0	430
M	2YUSJR1100000000	BaseAmount	2Y	US		0	510
N	2YUSJR2101110000	BaseAmount	2Y	US		0	520
O	2YUSJR3101110001	BaseAmount	2Y	US		0	530

# IG-20805 :Exporting the input tax code and the withholding tax code master data

Buyer : Core Administration → Data Import/Export

**Data Import/Export**

Exclamation marks (!) indicate tasks that completed with errors or warnings. Click **Refresh Status** to show current status.

Download Data Dictionary

Search Filters:

Task Name:

Import | Export | Web Service Status

Tasks	Integration Toolkit Names	Status	Last Imported ↓	Import
Import Tax Codes		Completed	09/23/2020 12:35:28 PM	<input type="button" value="Import"/>
Import Tax Components		Completed	09/23/2020 12:34:54 PM	<input type="button" value="Import"/>
Import Tax Type Mappings		Completed	09/23/2020 12:30:09 PM	<input type="button" value="Import"/>
Import Tax Types		Completed	09/23/2020 12:29:41 PM	<input type="button" value="Import"/>
Import User Data (Consolidated File)		Completed	09/22/2020 05:33:26 PM	<input type="button" value="Import"/>
Import Users		Error	09/22/2020 05:04:20 PM	<input type="button" value="Import"/>
Import ERP Commodity to Commodity Mapping		Completed	09/21/2020 04:40:39 PM	<input type="button" value="Import"/>
Import Invoice Exception Types		Completed	09/18/2020 01:07:25 PM	<input type="button" value="Import"/>
Import Invoice Exception Type Validation Data		Completed (!)	09/18/2020 12:19:39 PM	<input type="button" value="Import"/>
Import Invoice Exception Type Translations		Completed	09/18/2020 12:19:05 PM	<input type="button" value="Import"/>
Import Currency Mappings		Completed	09/18/2020 12:10:46 PM	<input type="button" value="Import"/>

## Import Tax Codes

**Data Import for Task "Import Tax Codes"**

Choose the operation you want to perform. Browse or specify the file which

Select Import Operation:

**Load**  
*Creates and modifies objects using the values in the import file. If a values in the import file.*

**Create**  
*Creates new objects in the database using the values in the import*

**Update Only**  
*Modifies existing objects using the values in the import files. If an **Important:** If you don't want to modify an object, don't include it in*

**If you are importing user group mappings:** The Update Only or replace existing mappings for all the groups in UserParentGroup.csv.

**Deactivate**  
*Deactivates objects. All the objects listed in the import file are deact*

Enter the location of the TaxCodeHeader.csv file:  
 TaxCodeHeader.csv

Enter the location of the TaxCodeDetails.csv file:  
 TaxCodeDetails.csv

# IG-20805 :Exporting the input tax code and the withholding tax code master data

Buyer : Core Administration → Tax Manager → Tax Codes

The screenshot shows the SAP Tax Codes administration interface. The navigation bar includes HOME, PROCUREMENT, CATALOG, ADMINISTRATION (selected), and MORE... The left sidebar lists various management tools, with Tax Manager expanded to show Tax Codes. The main content area is titled 'Tax Codes' and includes a search filter section with fields for ID (1Y), Name, Country/Region (Germany), and State. Below the filters is a table of tax codes:

ID	Name	Description	Country/Region
1Y		New Tax for DE	Germany

A 'Create New' button is visible below the table.

Details:

The screenshot shows the 'Tax Codes - Edit Tax Code' details page. It has tabs for 'General' and 'Details' (selected). The page title is 'Tax Codes - Edit Tax Code' and the subtitle is 'Edit an existing tax code'. Below this is a section for assigning tax components to the tax code, with the instruction: 'Assign tax components to the tax code and modify their order to define the sequence in which they are applied to line items.' The table below lists the assigned components:

Sequence	Tax Component *	Tax Rate	Applied On	
<input type="checkbox"/>	A	A/P Sales Tax 1 Inv.	5.0%	BaseAmount
<input type="checkbox"/>	B	A/P Sales Tax 2 Inv.	4.0%	BaseAmount
<input type="checkbox"/>	C	A/P Sales Tax 3 Inv.	1.0%	BaseAmount
<input type="checkbox"/>	E	A/P Sales Tax 1 Exp.	4.0%	BaseAmount
<input type="checkbox"/>	F	A/P Sales Tax 2 Exp.	3.0%	BaseAmount
<input type="checkbox"/>	G	A/P Sales Tax 3 Exp.	1.0%	BaseAmount
<input type="checkbox"/>	I	A/P Sales Tax 1 Use	3.0%	A
<input type="checkbox"/>	J	A/P Sales Tax 2 Use	2.0%	A
<input type="checkbox"/>	K	A/P Sales Tax 3 Use	1.0%	A

At the bottom of the table are buttons for 'Delete', 'Move Up', 'Move Down', and 'Assign Component'.

## IG-21022 : Enhancement to the interface to extract user master data via MDNI

### Customer Challenge

- Fix and enhance the end-to-end integration User Master upload from SAP ERP to Ariba Buyer or MDS via master data native interface (MDNI).

### Solution

- As part of this release, existing user interface is regenerated and enhanced in accordance with MDNI API to support end-to-end User Master upload
- Fields exported - Name, email, cost center, GL Account, User Group
  - ✓ Configure Ariba User HR event linkage in SPRO
  - ✓ Maintain user profiles for user master - Maintain relevant roles applicable for SAP Ariba solutions

### Key Benefits

- User Master data prerequisite for integration in various scenarios.
- Supports incremental export option to fetch the added/changed user records

# IG-21022 : Enhancement to the interface to extract user master data from SAP ERP via master data native interface (MDNI)

User in ERP backend  Report: ARBCIG\_MDNI\_USER  User replicated to Ariba Buyer / MDS

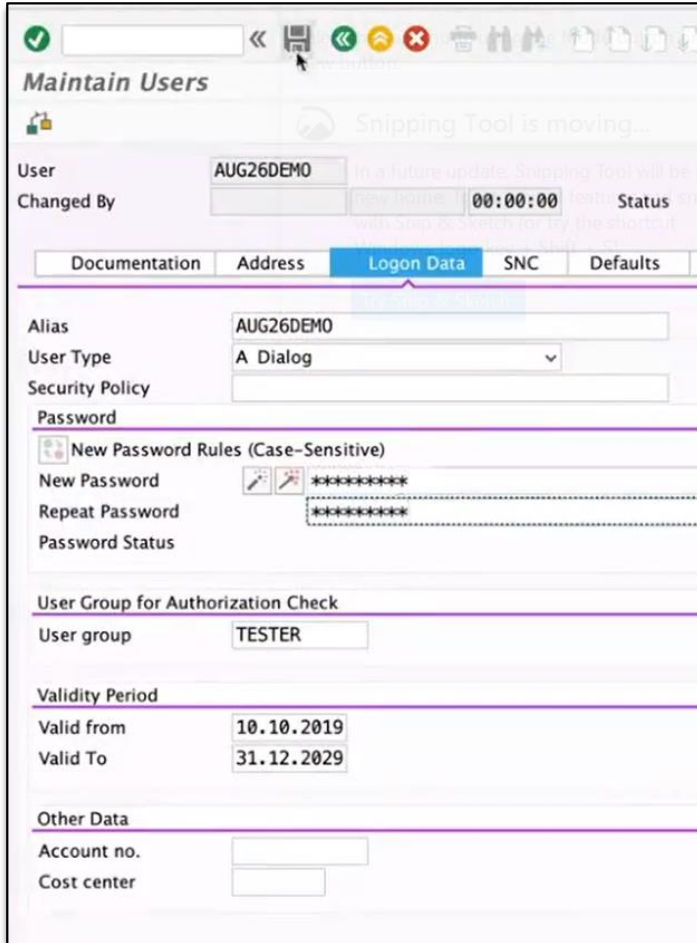

**Maintain Users**

User: AUG26DEMO

Changed By: [ ] Date: [ ] Time: 00:00:00 Status: [ ]

Documentation | Address | **Logon Data** | SNC | Defaults

Alias: AUG26DEMO

User Type: A Dialog

Security Policy: [ ]

Password

New Password Rules (Case-Sensitive)

New Password: [ ] Repeat Password: [ ] Password Status: [ ]

User Group for Authorization Check

User group: TESTER

Validity Period

Valid from: 10.10.2019 Valid To: 31.12.2029

Other Data

Account no.: [ ] Cost center: [ ]

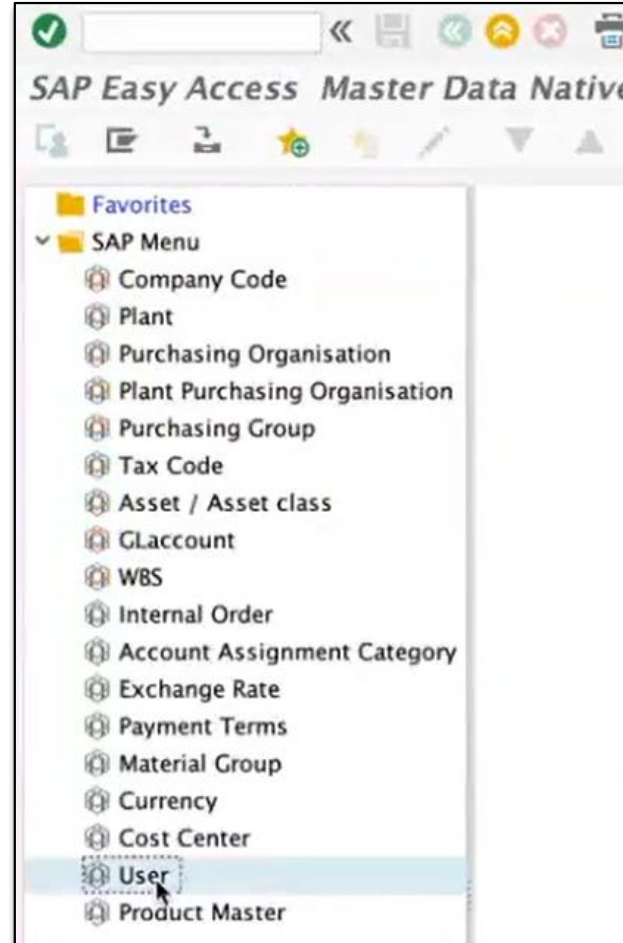

**SAP Easy Access Master Data Native**

**Favorites**

- SAP Menu
  - Company Code
  - Plant
  - Purchasing Organisation
  - Plant Purchasing Organisation
  - Purchasing Group
  - Tax Code
  - Asset / Asset class
  - GLaccount
  - WBS
  - Internal Order
  - Account Assignment Category
  - Exchange Rate
  - Payment Terms
  - Material Group
  - Currency
  - Cost Center
  - User**
  - Product Master

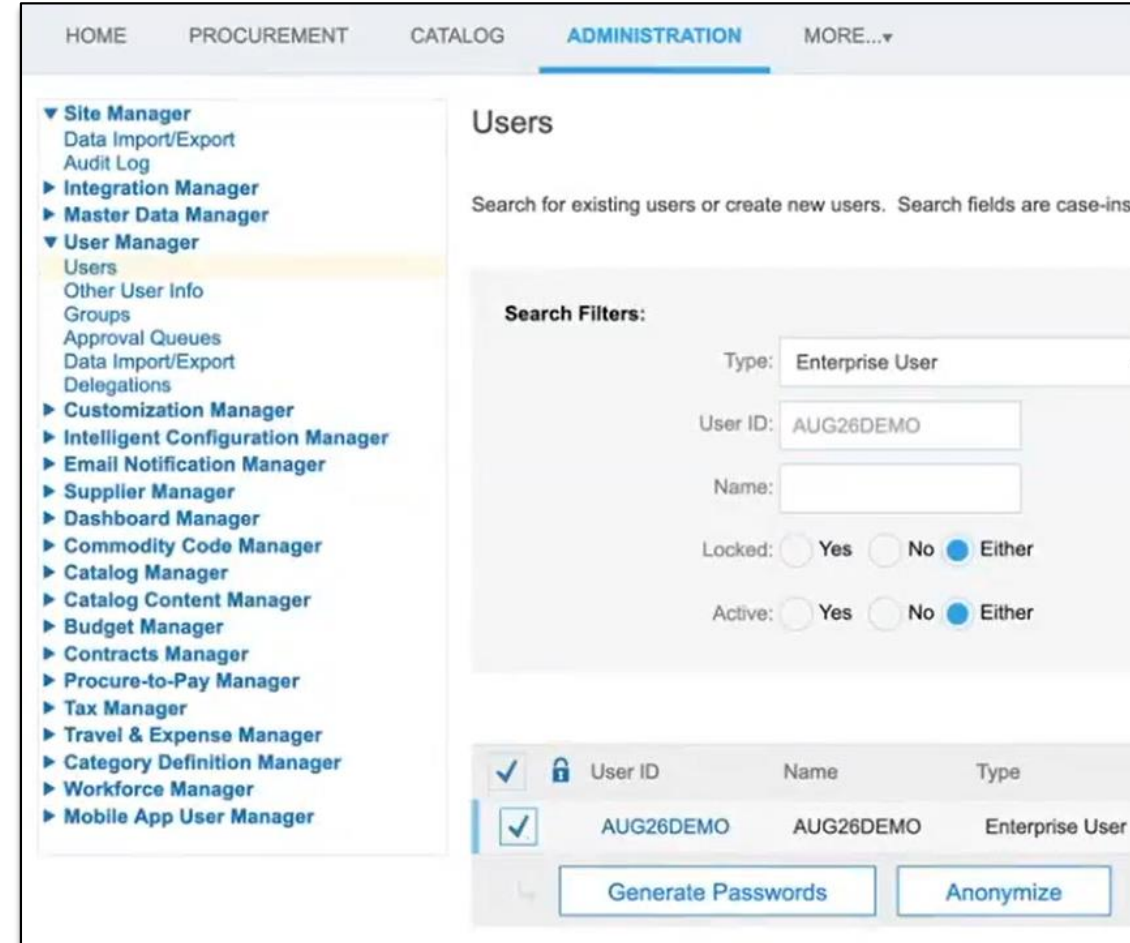

HOME | PROCUREMENT | CATALOG | **ADMINISTRATION** | MORE...v

**Users**

Search for existing users or create new users. Search fields are case-insensitive.

**Search Filters:**

Type: Enterprise User

User ID: AUG26DEMO

Name: [ ]

Locked:  Yes  No  Either

Active:  Yes  No  Either

<input checked="" type="checkbox"/>	<input type="lock"/>	User ID	Name	Type
<input checked="" type="checkbox"/>	<input type="lock"/>	AUG26DEMO	AUG26DEMO	Enterprise User

# IG-17025: Integrating scheduling agreements between SAP Ariba Sourcing and SAP ERP or SAP S/4HANA

## Customer Challenge

- In the past, buyers could only create purchase orders or contracts in SAP ERP or SAP S/4HANA.
  - Advanced Pricing Conditions and Scales were supported only for Contracts/Outline Agreement
- Integration between Ariba Sourcing or Contracts and SAP ERP or SAP S/4 HANA On-Premise

## Solution

- Support publishing a RFX Award with Advanced Pricing conditions & Scales from Ariba Sourcing to SAP ERP or SAP S/4 HANA On-Premise as a Schedule Agreement(LP or LPA).

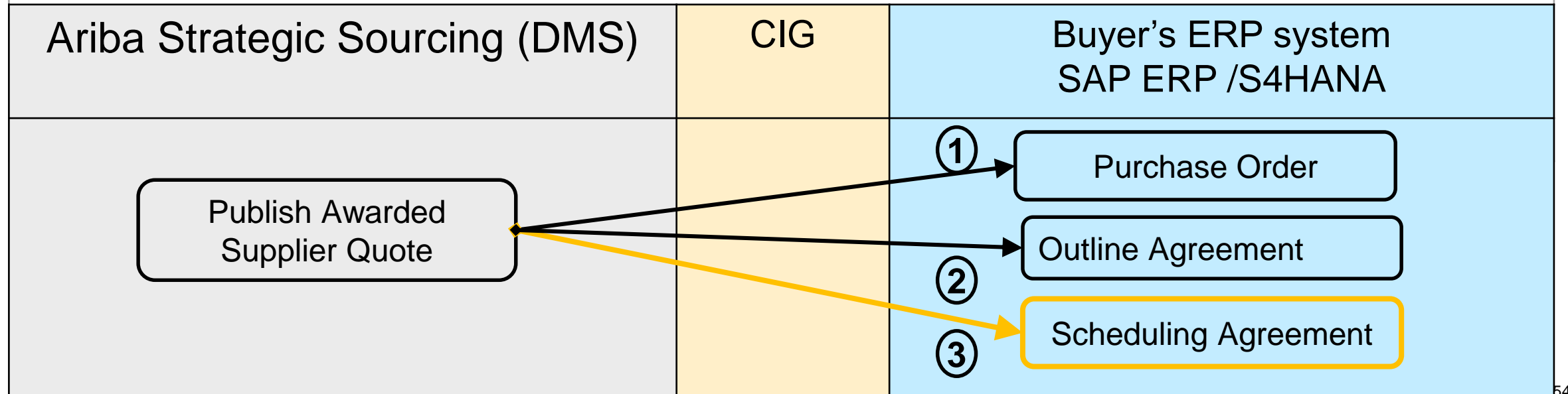

# IG-17025: Support for advanced pricing conditions and scales in scheduling agreements

## Supported pricing conditions

- Pricing conditions – Gross price, discounts, and surcharges for fixed amounts
- Price validity format - Monthly, quarterly, annually, and custom price validity
- Scale Types - From and To scales

## Restrictions

- Scheduling agreement must only contain material items, service items are not supported
- Deletion of validity period or scales for pricing conditions is not supported.
- SAP Ariba Contracts supports Fixed amount calculation type only. Scheduling agreements with the percentage values for surcharge and discounts or with graduated scales is not supported.
- This end-to-end integration does not support schedule lines in scheduling agreements.

## Key Benefits

- Buyers using scheduling agreements can shorten and simplify the entire process.
- Take advantage of the flexible pricing options with multiple breaks in time and price ranges.

# **New Feature Innovations: IES S2P Integrations**





# New Feature Innovations: IES S2P Integrations (S/4 HANA Cloud)

## ➤ IES Scope Item 4BL: Sourcing with SAP Ariba Sourcing

- IG-17112 Support for mappings-based integration of the Sourcing with SAP Ariba Sourcing (4BL) integration scenario
- IG-20806 Support attachment in Sourcing Integration in CIG - 4BL

## ➤ IES Scope Item 4QN: Sourcing for Central Procurement with SAP Ariba Sourcing

- IG-16468 SAP Ariba Cloud Integration Gateway support for the Central Procurement with Ariba Sourcing (4QN) integration scenario

## ➤ IES Scope Item 42K: Automation of Source-to-Pay with Ariba Network

- IG-14654 Support for order confirmations for lean services (42K)
- IG-17649 Support for quick enablement of suppliers on Ariba Network based on the purchase order sent from SAP S/4HANA Cloud to Ariba Network (42K)
- IG-17873 Support for goods return cancellation for purchase orders from SAP S/4HANA Cloud to Ariba Network (42K)

## ➤ IES Scope Item 4A1: Automation of Order-to-Invoice with Ariba Network

- IG-20266 Enhancements to Outbound Invoice enhancements for Automation of Order-to-Invoice with Ariba Network (4A1)

# IG-17112 : Support for mappings-based integration of the Sourcing with SAP Ariba Sourcing (4BL)

## Customer Challenge

- The 4BL integration scenario supports integration of SAP Ariba Sourcing with SAP S/4HANA Cloud through SAP Ariba Cloud Integration Gateway. Previously, the 4BL integration scenario support on SAP Ariba Cloud Integration Gateway was based on a passthrough model.

## Solution

- Mappings-based integration enables users to customize the integration, by using the SAP Ariba Cloud Integration Gateway mapping tool, to suit their business requirements.
- The mappings-based implementation of the 4BL integration scenario also supports attachments to transaction documents.

## Key Benefits

- SAP Ariba Cloud Integration Gateway supports the integration of custom fields between SAP Ariba Sourcing and SAP S/4HANA Cloud. Custom fields can be used when SAP Ariba creates custom mappings based on the customer's request.

# IG-16468 : SAP Ariba Cloud Integration Gateway support for the Central Procurement with Ariba Sourcing (4QN) integration scenario

## Customer Challenge

- Customers needs to run Central Sourcing using S4/HANA Central Procurement Hub solution that supports multiple Connected Systems (ERPs).
- CIG needs to extend the existing Ariba Sourcing and S/4 HANA Cloud integration to S/4 HANA Cloud Hub system to support Central Sourcing integration. We would also like to extend this integration to SAP S/4 HANA On Premise Hub system.

## Solution

- Support a new integration scenario with Ariba Sourcing and SAP S/4 HANA Hub system
- New CIG Document type: *CentralRequestForQuotation* & *CentralSupplierQuotation*
- Mapping transformation in CIG for all the interfaces as part of this integration.
- *ORIGIN flag* set in payload in CIG before sending it to Ariba Sourcing to indicate 4BL/4QN scenario..

## Key Benefits

- Get a seamless integration with S4/HANA Central Sourcing - Create a central RFQ in S4/HANA, integrate with Ariba Sourcing to create Sourcing Project; negotiate Terms & Conditions and finalize Awards in SAP Ariba Sourcing so that the Awards from Ariba Sourcing are sent to Central RFQ and then gets distributed to respective Connected Systems to create PO.

# IG-16468 : SAP Ariba Cloud Integration Gateway support for the Central Procurement (4QN)

## SOURCE TO PAY CENTRAL SOURCING FLOW

Legend:  Process step (mainly manual)  Process step (mainly automatic)  Start process  End Process

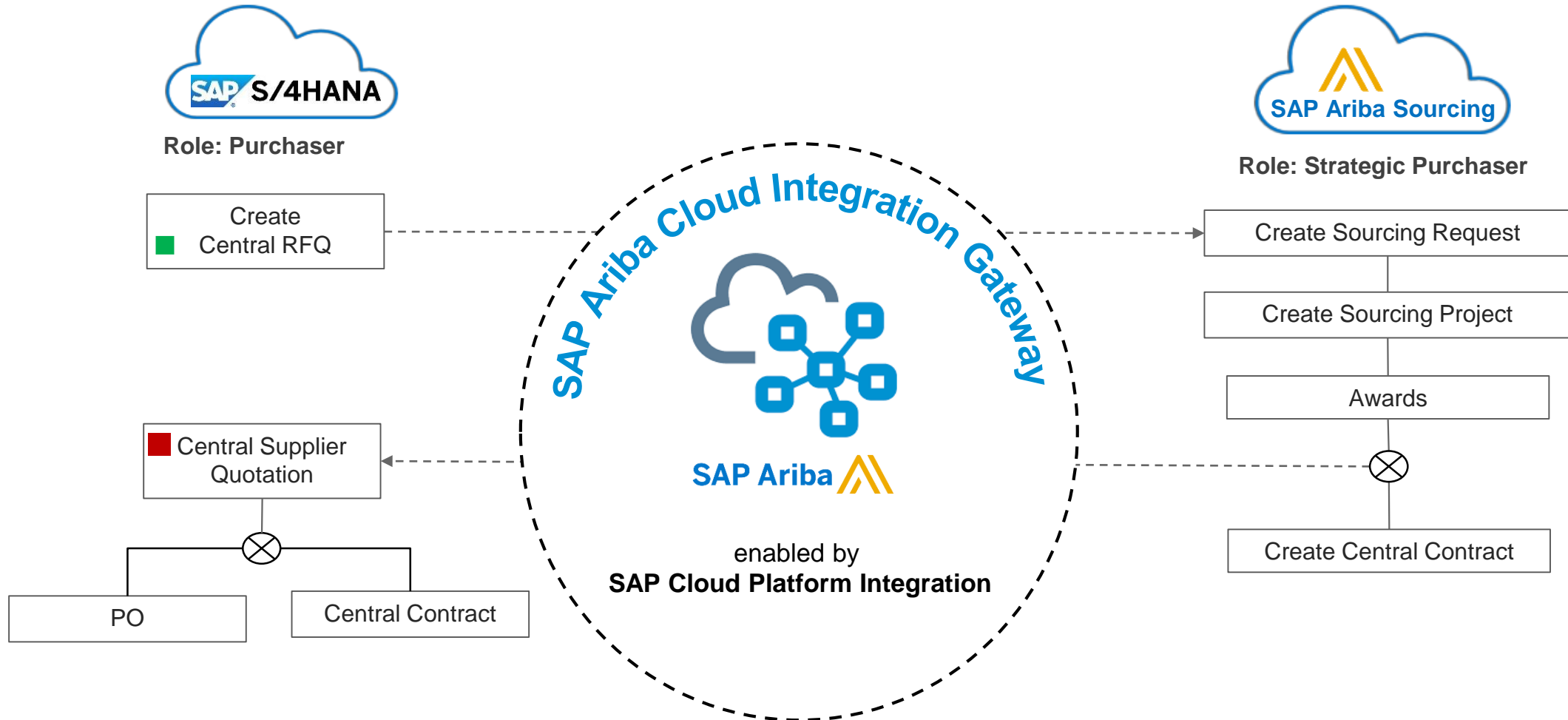

## IG-14654 : Support for Order Confirmations for Lean Services (42K)

### Customer Challenge

- S/4 HANA Cloud and Ariba Network integration supports order confirmations for material items, but not for planned lean service items. In addition, order confirmations for mixed item types (material and lean services) need to be supported

### Solution

- CIG integration has been enhanced to support Order Confirmation for Lean service items along with 'StartDate', 'EndDate' that a supplier enters while confirming a Lean PO
- 'Accept' and 'Reject' of entire Order or specific lines is supported (Backorder for lean service items is not supported)

### Key Benefits

- Without receiving an order confirmation, it is difficult for a buyer to know whether a supplier received the order and if it is in the process of fulfilment. This update will allow supplier to respond to an order which contains lean services and therefore provide better visibility to buyer.

# IG-14654 : Support for Order Confirmations for Lean Services (42K)

## Purchase Order Confirmation for Purchase Order with Material and Planned Lean Service Items in Ariba Network

Order Confirmation: OC-1322

Done

Previous

[Print](#) [Export cXML](#)

Detail

[History](#)

Confirmation #: OC-1322  
Notice Date: 17 Sep 2020  
Purchase Order: [4500011322](#)

### Line Items

Line #	Part # / Description	Customer Part #	Qty (Unit)	Need By	Ship By	Unit Price	Subtotal
10	Non-Catalog-Item	4	10.0 (HUR)	11 Sep 2020		70.00 EUR	700.00 EUR
	Software Development						
	Current Order Status:						
	10 Confirmed As Is (Service Period [Start: 26 Aug 2020 - End: 11 Sep 2020] - defaulted from Service Period in order )						
20	Non-Catalog-Item	SP001	1 (PCE)	25 Sep 2020		130.00 EUR	130.00 EUR
	MacBook - Laptop						
	Current Order Status:						
	1 Confirmed With New Date (Estimated Shipment Date: 17 Sep 2020; Estimated Delivery Date: 17 Sep 2020)						

# IG-14654 : Support for Order Confirmations for Lean Services (42K)

## Purchase Order Confirmation for Purchase Order with Material and Planned Lean Service Items in S/4 HANA Cloud

Document Overview On Messages Personal Setting Save As Template Load from Template Services for Object More

NB Standard PO  Supplier: 10300089 Inlandslieferant DE (ARB Lean ... Doc. Date: 17.09.2020

Header

Display Scope: ALL All Items Char. Display:

S...	Itm	Glob...	A	I	Material	Short Text	PO Quantity	OUn	S...	C	Deliv. Date	Net Price	Curr...	Per	OPU	Matl Group	Plant	
<input checked="" type="checkbox"/>	10		K		4	Software Development	10,0	HR	<input type="checkbox"/>	D	11.09.2020	70,00	EUR	1	HR	P001	1010	
<input type="checkbox"/>	20		K		SP001	MacBook - Laptop		1	PC	<input type="checkbox"/>	D	25.09.2020	130,00	EUR	1	PC	YBPM01	1010
<input type="checkbox"/>										<input type="checkbox"/>	D	13.08.2020		EUR		A001	1010	

Item: 1 [10] 4 , Software Development

Material Data Quantities/Weights Delivery Schedule Delivery Invoice Conditions Account Assignment Texts Delivery Address **Confirmations** Condition Control Retail

Conf. Control: 0001 Confirmations Order Ack.:   Ackowl.Req  Rejection Ind.

CC	D	Delivery Date	Time	Quantity	Reference	Created on	Start Date	End Date	Inb. Deliv.	Itm	HL It...	Batch	Quantity Reduced	M	MPN material
AB	D	11.09.2020		10,0	OC-1322	17.09.2020	26.08.2020	11.09.2020		0	0		0,0	<input checked="" type="checkbox"/>	

# IG-17649 : Support for quick enablement of suppliers on Ariba Network based on the purchase order sent from SAP S/4HANA Cloud to Ariba Network (42K)

## Customer Challenge

- Buyers who are on S/4 HANA CE cannot send a PO to their Vendors who are not enabled on Ariba Network. These PO's fail on Ariba Network.

## Solution

- Support quick enablement of suppliers on Ariba Network based on Purchase order sent from S/4 HANA to Ariba Network
- CIG integration has been enhanced to enable Purchase Order 'routing' to Supplier's email address
- This features will be for all types of PO originating from S4 to AN

## Key Benefits

- S/4 HANA Buyer can initiate quick enablement of supplier via Purchase Order if supplier is not already enabled on Ariba Network



# IG-17873 : Support for goods return cancellation for purchase orders from SAP S/4HANA Cloud to Ariba Network (42K)

## Customer Challenge

If a buyer wants to return goods for any reason (defective, damaged etc) they can do so via a goods return document. However, if errors are made during input of the goods movement transactions, it might be necessary to reverse the goods return document.

During prior releases of IES 42K scope item, only Goods Receipt (101), Goods Receipt Cancellation / Reversal (102) and Goods Return for Purchase Order (122) were considered. 'Goods Return Reversal / Cancellation (123)' for Purchase Order is not supported.

## Solution

- CIG integration has been enhanced to Goods Return Reversal/cancellation to send quantity as a 'negative' value and setting the 'type' to 'returned' on the cXML ReceiptRequest document

## Key Benefits

- S/4 Buyer should be able to reverse a Goods Return for a Purchase Order and integrated with Ariba Network

# IG-17873 : Support for goods return cancellation for purchase orders from SAP S/4HANA Cloud to Ariba Network (42K)

## Sample Goods Return Reversal document in Ariba Network:

Item	Order Line Number	Part #	Customer Part #	Batch #	Customer Batch #	Packing Slip ID	Packing Slip Date	Qty (Unit)	Delivery Address	Type	Unit Rate	Amount	Status
Purchase Order: 4500044288													
1	10	70502				KVGR2_122		-3.00 EA	Not Specified	Returned			
Description: Non Carbonated Sugar Drinks (Case12)													
Comments													

# IG-20266 : Enhancements to Outbound Invoice enhancements for Automation of Order-to-Invoice with Ariba Network (4A1)

## Customer Challenge

**VAT ID not captured on Invoices:** On an Invoice, the supplier's VAT ID is always required. The buyer's VAT ID is required for intra-European Union transactions. Intra-EU is defined as trade within the European Union, where the From and To country codes are in the European Union and are different countries. This information is needed on identifying related tax calculations.

**Tax Values** - There can be more than one taxes that gets sent on Invoice which can be at header or line that needs to be conveyed by the supplier.

## Solution

- CIG integration has been enhanced to send the Buyer and Supplier VATID on an Invoice including Tax information at Invoice header and line items

## Key Benefits

- Improved product meeting business requirements in the Order to Cash process.

# New Feature Innovations: IES S2P Integrations (S/4 HANA)

- **Starting with S/4 HANA 2020**, S/4 API based integration (without CIG AddOn) for S/4 HANA solution scope items is available
- S/4 API based integration is available only for S/4 HANA 2020 Greenfield customers
- S/4 HANA 2020 customers may choose either API based integration **and/or** AddOn based integration (Co-existence of CIG AddOn & API integration)
  - E.g. API based integration for Guided Buying (scope item : 2NV) while leveraging CIG AddOn integration for Ariba Network Commerce Automation
  - E.g. CIG AddOn integration for Ariba Network Commerce Automation while leveraging API based integration for Ariba Network Quote Automation (Scope item: 42K)
  - E.g. CIG AddOn for Ariba Network Commerce automation while leveraging API based integration for Seller integration (Scope item: 4A1)

# S/4 HANA Integration w/CIG AddOn and S/4 API - Coexistence

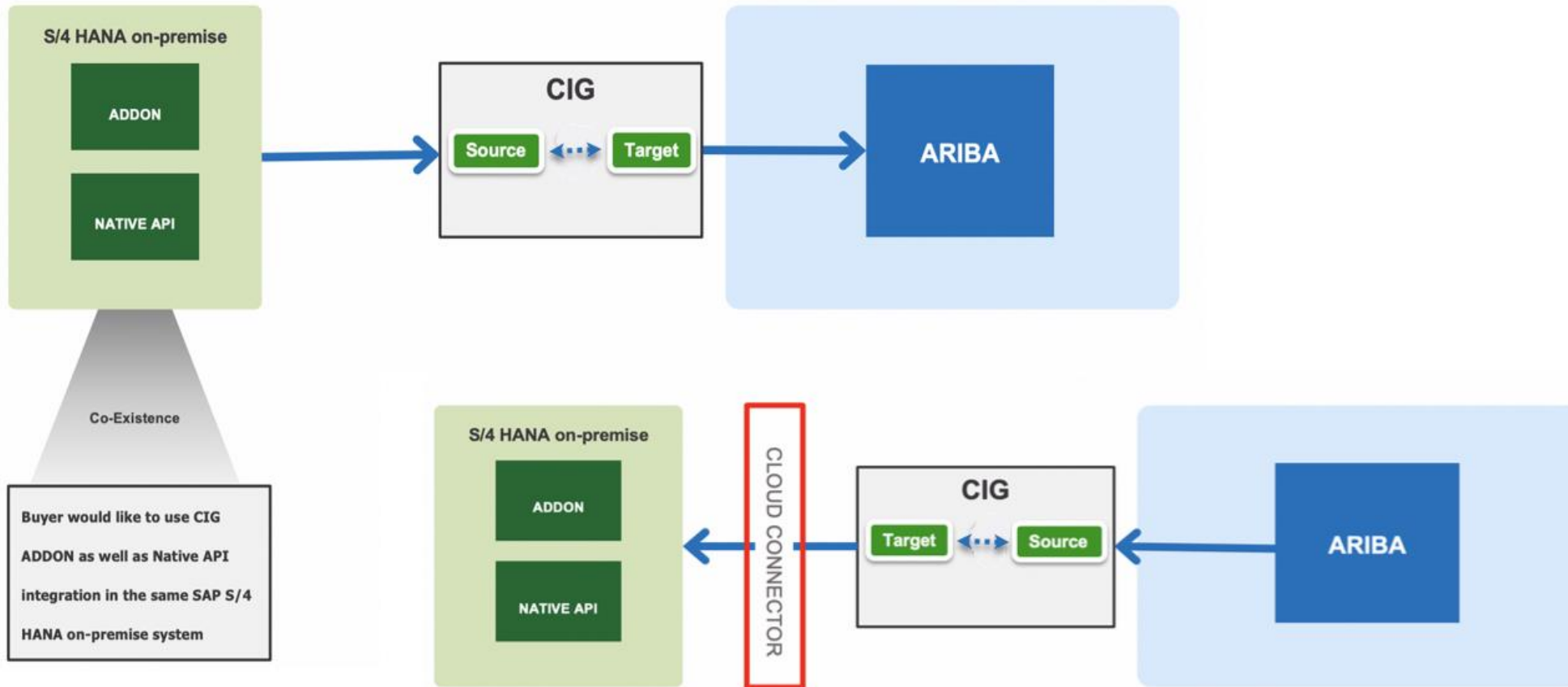

# S/4 HANA Integration w/CIG AddOn and S/4 API: Co-existence

Home My Configurations Document Validator Connectivity Tool Transaction Tracker Resources Master Characteristics Test Central Http Logs

Project Wizard Cancel

1 Basic Information  
2 **Connection**  
3 Mappings  
4 Cross Reference  
5 Test

Please Provide Your Connection Details

\*Transport Type: CloudConnector  
\*Environment: TEST / PRODUCTION  
\*Name: HYBRID  
\*System ID: QKRCLNT521

Connect to Backend

\*Document Type: ANY  
\*Domain Name: 2nv.guidedbuying.com  
\*Port: 44300  
\*Client ID: 521  
\*Location ID: QKR5211  
Authentication Type: Basic  
\*Username: 2NV\_INBOUND  
\*Password: \*\*\*\*\*

Connect Trading Partner to CIG:

Authentication Type: Basic  
Username: P000983

Transport Type = CloudConnector

# New Feature Innovations: IES S2P Integrations (S/4 HANA)

With S/4 HANA FPS0, following IES scope items are released

- **IES Scope Item 2NV: Guided Buying Capability with SAP Ariba Buying**
  - IG-18462                      Integration support for Guided Buying Capability with SAP Ariba Buying (2NV) for SAP S/4HANA
  
- **IES Scope Item 3EN: Guided Buying for Central Procurement with SAP Ariba Buying**
  - IG-18463                      Integration support for Guided Buying for Central Procurement with SAP Ariba Buying (3EN) for SAP S/4HANA
  
- **IES Scope Item 4A1: Automation of Order-to-Invoice with Ariba Network**
  - IG-17212                      Integration support for Automation of Order-to-Invoice with Ariba Network (4A1) for SAP S/4HANA
  
- S/4 API based integration is made available in multiple releases (S/4 HANA 2020 FPS0 / FPS1)
  - API based integration for additional IES scope items will be released with upcoming releases

# Reminder

## Please remember to provide Survey feedback

- If not already visible, click the Survey button at the bottom of the screen.
- Answer the 3 questions posed.
- Click Submit.

Your feedback is used to continually improve our customer engagement activities for our quarterly product releases.

Thank you for taking the time to share your thoughts with our team!



The screenshot shows a dark navigation bar with five icons: a question mark, a stylized 'A' logo, a red 'LIVE' button, a purple 'Q&A' button, and a blue 'Survey' button with a white checkmark. The 'Survey' button is highlighted with a yellow rectangular box.

Below the navigation bar is a survey form titled "Survey". The form content is as follows:

Survey

Event Survey

Your feedback on this webinar is greatly appreciated. We review every response in order to make continuous improvements to these presentations.

1. How strongly would you recommend this webinar to your peers?

2. Are you willing to be contacted to provide survey feedback on release readiness content?

3. Provide any comments you have regarding this session or the release materials:



# General Information **Session Materials**

Recordings and presentations will be posted on the Release Readiness tab/tile in SAP Ariba Connect. See the Release Feature List and What's New links on the left side of the page for detailed information. Note naming convention update and visit the Previous Releases Archive and Roadmap tiles at bottom right of page.

**Release Readiness** [Have a question?](#)

### Release Feature Content

Release Feature Information	What's New Guide	Feature Overview Webinars
<p>What's new in the <b>SAP Ariba 2011</b> release?</p> <p>Feature details are available on our <a href="#">feature list page</a>.</p> <p>Highlights of innovation included in this release can be viewed on our <a href="#">blog</a>.</p>	<p>Individual release guides have been consolidated into one convenient <a href="#">"What's New in SAP Ariba"</a> guide.</p> <p>Learn more about the benefits of the new consolidated "What's New in SAP Ariba" guide <a href="#">here</a>.</p> <p>Did you know all SAP Ariba help, including product documentation, is now publicly available on the <a href="#">SAP Help Portal</a> - no log in required.</p>	<p><b>Register Now For The 2011 Release Feature Overview Webcasts</b></p> <p>SCHEDULE</p> <p>Guided Sourcing Webcast - <b>Thursday, Oct 29</b> Supplier Management and Business Network Webcast - <b>Tuesday, Nov 3</b> Source To Contract Webcast - <b>Wednesday, Nov 4</b> Procure To Pay Webcast - <b>Thursday, Nov 5</b> Cloud Integration Gateway Webcast - <b>Monday, Nov 9</b> Foundation Services Webcast - <b>Tuesday, Nov 10</b></p> <p>Use the link below to register for one or multiple sessions.</p> <p><a href="#">2011 Release Feature Overview Registration</a></p> <p>We strongly encourage you to test your computer prior to the session to ensure the minimum technical requirements are met. Look for the Test Your System link in your registration confirmation email.</p>

### Release Calendar

Activity	Date*
October Service Pack	10/16/2020
cXML DTD v 1.2.048 (pre-release)	10/21/2020
SAP Ariba 2011 Release	11/13/2020
December Service Pack	12/11/2020
January Service Pack	01/15/2021

[2020/2021 Release Calendar](#) [view](#)

**\*Disclaimer:** The release dates above reflect current SAP Ariba planning. A notice confirming the [quarterly release](#) dates will be sent 3-weeks prior to each release. A notice confirming the [monthly deployment](#) dates will be sent 2-weeks prior to each deployment. SAP Ariba may change the schedule at any time without notice and assumes no responsibility for errors or omissions.

Last updated: Oct 22, 2020

### Additional Readiness Resources

**Release Updates**

Updates related to the release will be added here.

Chat bot

# Thank you.

# Appendix: Additional information of possible interest

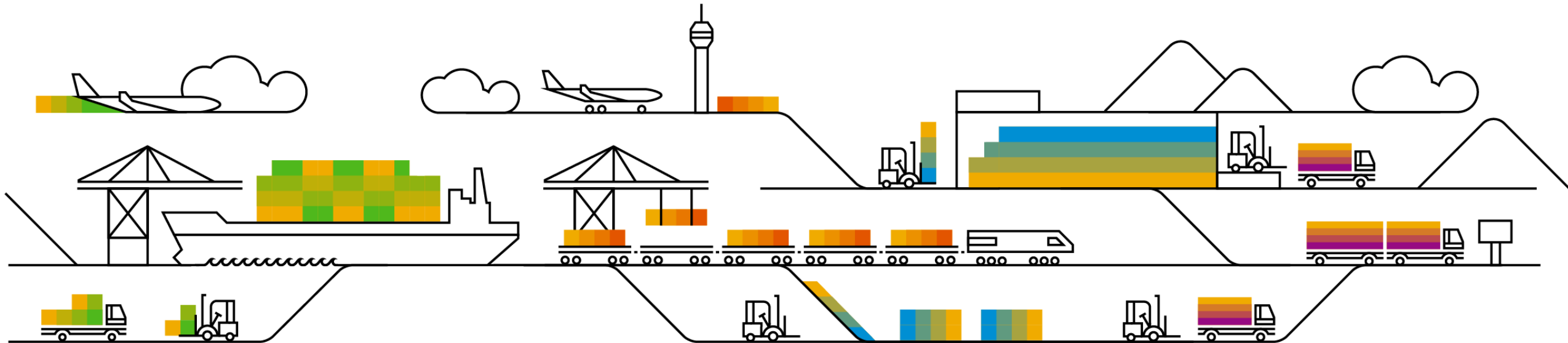

# Communications Notice Recipients

Release Notifications are sent to all Designated Support Contacts by default and any other users that subscribe.

## Best Practice:

- Encourage relevant team members to subscribe by clicking their name in the top right corner and select Subscriptions
- Create a distribution list for others that need to know and add as an additional email

The screenshot shows the SAP Ariba Connect interface. At the top, there is a search bar and a user profile for Rick Cox. A dropdown menu is open, showing options: User Profile, Change Password, Subscriptions (highlighted with a red box), Designated Support Contacts, Entitlements, Environments, Contact Us, Turn On Background, Help, and Log Out. Below the menu, there are three sections for subscription management:

- Downtime/Security Notifications:** Includes a 'Subscribe' button and a note: "Notifications regarding scheduled/unscheduled downtime and security information/bulletins. Note: Internal users will not receive this regardless of their subscription options. You may request access to the 'DL AR Notification' distribution list [here](#)."
- Product Release Information:** Includes a 'Subscribe' button and a note: "Notifications regarding new product releases, new features, and service pack availability. Note: Internal users will not receive this regardless of their subscription options. You may request access to the 'DL AR Notification' distribution list [here](#)."
- Discussion Forums:** Includes a section for "Discussion Forums and Subscriptions" with a list of forums and their subscription status (e.g., Sourcing and Supplier Enablement, Procurement and Invoicing, Ariba Network, Cloud Integration).

DSC view with ability to add additional email

This screenshot shows the subscription options for Downtime/Security Notifications and Product Release Information. Each section has a 'Subscribe' button, an 'Unsubscribe' button with a question mark, and an 'Additional Email' field with a question mark. The 'Additional Email' field is currently empty and has a placeholder text '<Optional Additional Email>'. The text 'Notifications regard' is visible to the right of each section.

# Historical release information **Archive page**

Prior release materials grouped by product/solution area for quick reference.

Listed in chronological order of most recent to oldest update from top to bottom of page.

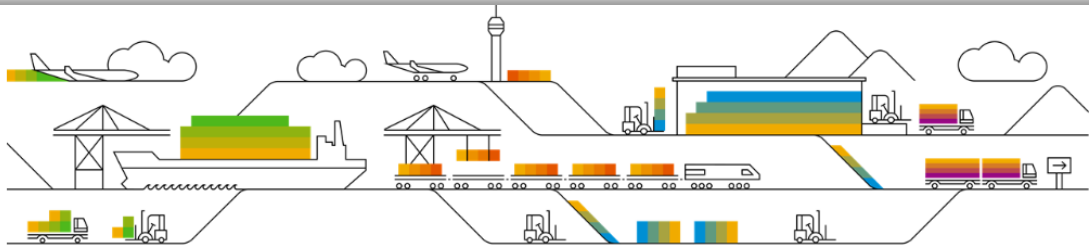

This page includes links to information on features delivered in previous SAP Ariba releases.

Release Guides for past applications releases can be accessed [here](#).

Release Guides for past Ariba Network releases can be accessed [here](#).

## Strategic Procurement



Sourcing [2019](#) [2018](#) [2017](#)  
 Direct Materials Sourcing [2019](#) [2018](#) [2017](#)  
 Contracts [2019](#) [2018](#) [2017](#)  
 Supplier Management & Risk [2019](#) [2018](#) [2017](#)  
 Spend Analytics [2018](#) [2017](#)

## Operational Procurement



Buying & Invoicing [2019](#) [2018](#) [2017](#)  
 Guided Buying [2019](#) [2018](#) [2017](#)  
 Catalog & Spot Buy [2019](#) [2018](#) [2017](#)

## SAP Ariba Customer Readiness Resources 2018 Releases:

### sourcing, contracts, & spend analysis

This page includes a list of features delivered in the 2018 calendar year for SAP Ariba Sourcing, Contracts, and Spend Analysis customers. Detailed information on all features can be found in the release guides and other documentation located on SAP Ariba Connect. Supplemental knowledge transfer materials are available for some features. Click the play or PDF icons to access the materials.

For additional information on the monthly release model see the About Release Readiness link on the Release Readiness tile of SP Ariba Connect.

### April

#### Update Material Master items in CLID from sourcing award

With this solution users should be able to update line items into a CLID from a Sourcing Award.

Mandatory



SAP Ariba Contracts  
SAP Ariba Sourcing

#### Append or update line items in contracts from a sourcing award without manual amendment of the contract workspace

This feature will ensure that line items from a sourcing award can be updated or amended in to a contract without manually changing the status of the workspace.

Mandatory



SAP Ariba Contracts  
SAP Ariba Sourcing

With this solution, all contracts - draft, draft amendment and published contracts will be listed from the sourcing award. When a user selects a published contract, application will create Price Update Amendments automatically, update the contract line items document by adding or updating line items, then close the amendment.

#### Control the deletion of line items from a Contracts Line Item Document (CLID)

This feature provides users the option to disable line items in the CLID thus preventing further edits while retaining the line item on the User Interface(UI) for future reference.

Mandatory



SAP Ariba Contracts

### March

#### Read-Only Terms in Line Items

With this feature, customers can make terms of line items in sourcing and contracts as read-only.

**Note: Though listed on this page and in the release guide, this feature was not made available with the March 2018 release. It is planned to be available with a later release.**

Mandatory



SAP Ariba Sourcing  
SAP Ariba Contracts